



Fixing Guide

November 2016

– Contents –

	PAGE
Product Information	3
No Special Tools Required	3
Storing the Product	3
Product Description	3
TapcoSlate Markings	4
Pitch, Gauge, and Coverage	4
Hip and Ridge Dimensions	4
Product Ratings and Certification	5
British Board of Agrément (BBA) Certification	5
Recycling	5
Fastener Recommendations	5
Roof Decking Materials	5
Roof Venting	6
Installation Guidelines	6
Spacing Between the Slates	6
Laying Out ½ Slates or Cut Slates	6
Preparation	6
Hip Roof Layout	6
Felt and Batten Roof	8
Ridge Cap Finishing	10
Valleys	11
Open Valley Design	11
Closed Valley Design	12
Flashings	12
Step Flashings	12
Apron (Roof to Wall) Flashing	13
Counter Flashing	13
Vent Flashings	14
Soil Stack	14
Pitch changes	14
Chimney Saddles	15
Hip & Ridge Detail	15
Ridge-to-Hip Intersection	17
Special Instructions	18
Installation onto a Fully Boarded Roof on Pitches of 14° up to 22.5°	18
Installation in Exceptionally High Wind Areas	19
Ventilation: RidgeMaster/HipMaster	20
RidgeMaster Plus & HipMaster Installation Guidelines	20
Ridgetree Construction – Boarded Roof	21
Truss Construction – Boarded Roof	21
Ridgetree Construction – Battened Roof	22
Truss Construction – Battened Roof	22
Fascia Vent – Boarded Roof	23
Roof to Wall/Apron Vent – Boarded Roof	23
Fascia Vent – Battened Roof	24
Roof to Wall/Apron Vent – Battened Roof	24
Continuous Dry Verge System	25
Turret Installation	26
TapcoSlate Accessories	27

– Product Information –

No Special Tools Required

- Hand fastened (hammered) or fastened with a pneumatic nail gun.
- Sharp utility blade or a standard circular saw.
- Tape measure, pry bar, tin snips.
- Chalk line with blue chalk (do not use red chalk).

Storing the Product

For proper installation, the slates need to be stored on the original pallet on a flat surface. Proper storage of the product at the job site is important. The slates are cambered to ensure that maximum pressure is transferred to the leading edge of the slate during installation. **Do not double stack pallets.**

Conditions: Perform work when existing and forecasted weather permits. Work should be performed in a safe and professional manner and when ambient weather conditions are within the limits established by TapcoSlate roofing products.

Storage: TapcoSlates should not be stored on roof decks in such a manner as to over-stress and/or damage the deck and supporting structure.

Cold Weather Installation: TapcoSlates should be stored in original packaging in a storage facility where the temperature meets or exceeds 7°C. Use protective coverage over all pallets while being temporarily stored on-site. TapcoSlates must be conditioned at a temperature no lower than 7°C for twenty-four (24) hours prior to use. TapcoSlate may be installed at temperatures as low as 0°C but must be hand fastened, the use of a pneumatic gun below 7°C will result in cracking and webbing in the fastened area. Be sure to follow the manufacturer's installation requirements for all underlay or membrane and any other applications. Comply with any and all local building regulations. **Note of Caution:** The slates can be slippery under certain conditions and job site safety procedures should be enforced.

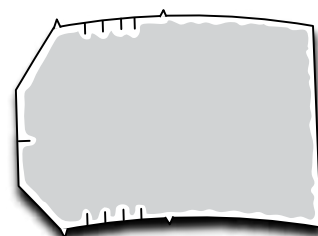

Product Description

TapcoSlates are manufactured from a recyclable blend of limestone and polypropylene, and are made from multiple natural patterns. The slate measures nominally 17.5" (445mm) in height and 11.6" (295mm) in width. The ridge cap measures nominally 6" (152mm) by 18" (457mm).

- Warranty – 40-year.
- Weight (slate) – Nominal 0.7 kgs.
- Weight (ridge cap) – Nominal 0.7 kgs.
- Ridge – 5.5 per linear metre.
- Hip – 5.5 to 6.5 per linear metre (depending on gauge)
- Packaging – Pallet: 1600 slates (1.04 tonnes), Bundle: 25 slates (16.25 kg).
- Batten Size – 2" (50mm) by 1" (25mm) treated battens (minimum).
- Thickness of roofing board – 0.7" (18mm) OSB.
- Fixing – Large-headed galvanised 1.2" (30mm) by 0.1" (2.5mm) steel nails (using hammer or nail-gun). Aluminium or copper nails may also be used, but driving them through the slate may cause bending. Longer 3" (76mm) nail required for fixing ridges and hips.
- Cutting – Fine-toothed handsaw, jigsaw, circular saw, or sharp utility blade.
- Minimum pitch – 14.5° (Board & Batten), 14° (Fully Boarded).
- Maximum pitch – 90°.
- No sorting required.

Please note: the diagrams in this guide are for illustration purposes only, actual sizes/placement may vary from those shown. If in doubt, please contact our technical department for advice: +44 (0)1482 880478.

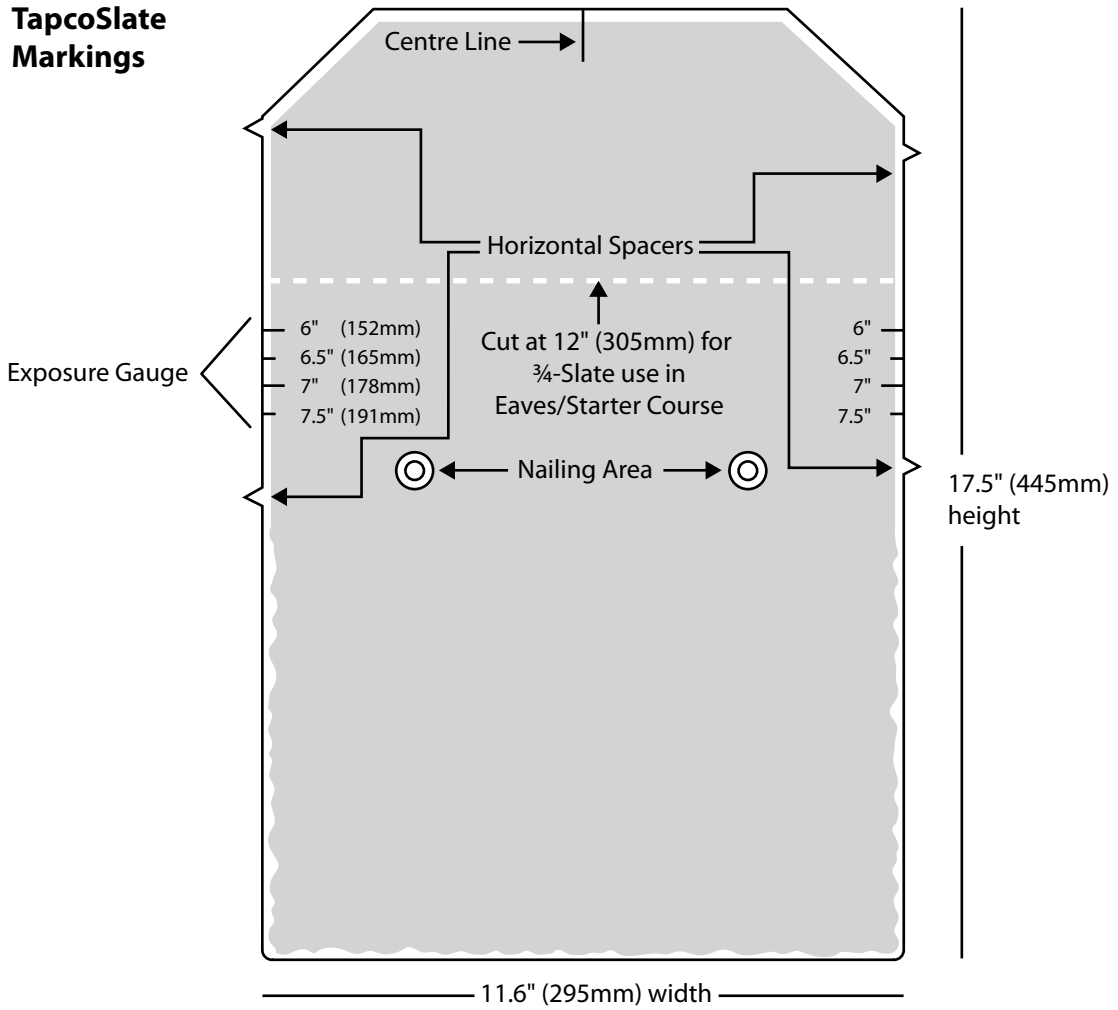

Pitch, Gauge, and Coverage

ROOF PITCH	GAUGE	SLATES PER M ²
14.5* to 25 degrees (fully boarded or felt & battens)	6" (152mm)	22
25 to 27.5 degrees (fully boarded or felt & battens)	6.5" (165mm)	20
27.5 to 30 degrees (fully boarded or felt & battens)	7" (178mm)	19
above 30 degrees (fully boarded or felt & battens)	7.5" (191mm)	18

* The minimum recommended pitch and lap may be influenced by special circumstances, please contact our technical department for advice.

IMPORTANT:

Advice from our technical department should be sought when installing on high buildings and/or in exceptionally windy areas.

Hip and Ridge Dimensions

- Length:17.5" (445mm)
- Height:5.9" (150mm)
- Exposure:6" (152mm) to 7.5" (191mm)
- Pre-formed Pitch:Universal

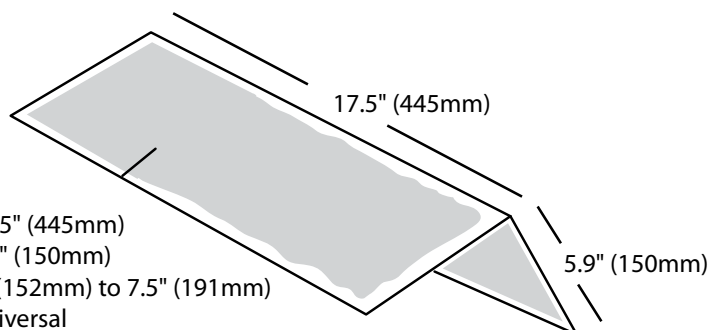

Product Ratings and Certification

- Hail Rating – Class IV.
- Fire Rating – BS476 Part 3, Boarded Roof SAA, Battened Roof SAC.
- Wind-driven Rain/Wind Uplift – Miami Dade TAS-100 (110 mph wind-driven rain) No water infiltration through sheathing. No slate cracked, split or lifted.
- ICC: ESR-2745.
- Texas Department of Insurance #RC-155.
- Florida Building Code PDM 7479.
- Accelerated Ultra Violet Exposure – Slate exhibited virtually no fade and with no trace of cracking or splitting.
- Freeze-thaw Cycle – No signs of damage or cracking after 300 cycles.
- Water Absorption – No appreciable weight gain.
- Water Permeation – Slate shown to be impermeable.
- Temperature Cycling – No signs of cracking, curling, deformation, or visible expansion.
- BBA Product Certification.



British Board of Agrément (BBA)

The BBA is the UK's major authority offering approval of construction products, systems and installers.

KEY FACTORS ASSESSED:

Strength – the products have adequate strength to resist the loads associated with the installation of the roof.

Properties in relation to fire – the products will enable a roof to be unrestricted under the Building Regulations.

Liquid water penetration – the products resist the passage of moisture into the building.

Durability – under normal service conditions the products will provide a durable covering with a service life of in excess of 20 years.

Recycling

TapcoSlate is 100% recyclable, but because the product is not marked with a recycling symbol or logo the contractor should contact a local recycler to make the necessary arrangements, stating that the product is "mineral-filled Polypropylene" plastic.

Fastener Recommendations

Slates should be applied using two (2) galvanised/stainless steel or copper fasteners with a minimum 3/8" (10mm) diameter head and minimum length of 30mm. Corrosion resistant fasteners are always recommended, especially in coastal areas.

The length of the Hip & Ridge fastener should be a minimum length of 2" (51mm) over the slates and 3" (76mm) over ridge vent.

Note: Caution should always be used to ensure against over/under penetration of the fastener. **Do not over-drive the fastener.** The fastener head should be contacting the slate within the centre of the nailing target circle.

All slates will be attached with two fasteners, as per these instructions.

Improper fastening can compromise the roof system and voids the manufacturers' warranty.

Roof Decking Materials

- Minimum of 23/32" (18mm) plywood decking, solid wood decking, or oriented strand board (OSB).

Roof Venting

Roof ventilation is necessary for the longevity of the roof system. Having a cool attic in the summer and a dry attic in the winter helps prevent damage to building materials, reduce energy consumption, and prevent ice damming. During hot months, an un-vented roof system will maintain a higher surface temperature, thus shortening the life of any roof system.

During winter months ventilation is a key factor to remove moisture from the attic. Warm moist air inside a building travels up toward the attic in winter months. Problems occur when water vapour comes in contact with cold building materials and condensates. The structural elements of the attic will absorb moisture and over time may lead to rotting wood and/or mould.

With a balanced ventilation system split between the ridge and soffit, 1 square foot (0.09m²) of net free area is required for every 300 square feet (27.9m²) of attic floors space.

It is required to have 1 square foot (0.09m²) of ventilation for every 150 square feet (13.9m²) of attic floor space if this balance cannot be achieved. Ventilation is necessary for extended life of the roof system. TapcoSlate roofing products will not warranty an un-vented roof and/or improperly vented roof system.

– Installation Guidelines –

Spacing Between the Slates

0.25" (6mm) spacer tabs are provided on every slate to aid in maintaining consistent spacing. The spacers will allow for any movement of the roof deck and expansion/contraction of the slate (although thermal expansion is highly unlikely in European climates).

Laying Out ½ Slates or Cut Slates

When beginning or finishing with a cut piece of slate, the cut edge should be installed inward. The manufactured edge should be installed to the outside edge of the roof. This is to maintain an acceptable roof appearance along the gable edge of the roof.

The centre mark of the slate can be used as a guide to cut ½-slates. This can also be used as a guide to keep courses straight and to assist in maintaining the proper 0.25" (6mm) spacing when aligning with intermittent vertical chalk lines. **DO NOT install slates smaller than 3" (76mm).**

Preparation

Inspect all areas of the roof surface to be covered.

1. The surface area must be uniformly flat, smooth, sound, clean and free of irregularities.
2. Examine roof sheathing to verify that sheathing joints are supported by framing and blocking and/or metal clips.
3. Verify that substrate is sloped for drainage and completely anchored to sound framing. Any foreign particles shall be cleaned from interlocking areas to ensure proper seating and to prevent moisture intrusion and ice damming. Proper provisions must be made for flashings and roof penetrations.
4. Even though metal flashing and other specialty flashings may not be the responsibility of the roofing contractor, these items must be in place prior to the roof slate installation. Work by other trades which penetrate the roof plane must be completed.
5. Product handling and storage on a flat surface is very important. TapcoSlate has a cambered design to ensure that the maximum pressure is transferred to the leading edge of the roof slate during the installation process. Do not double stack pallets.
6. Technical Bulletins are available to address specific aspects and/or requirements as they relate to certain applications. Please consult the website (www.tapcoroofingproducts.com) or call us (+44 (0)1482 880478) for this information.

Hip Roof Layout

1. Initial starting points may be from left side, right side or centre of the area to be installed. 0.25" (6mm) spacer tabs are provided on every roof slate.
2. A full slate can be cut into ¾ size to create an eaves or starter slate for the starter course.

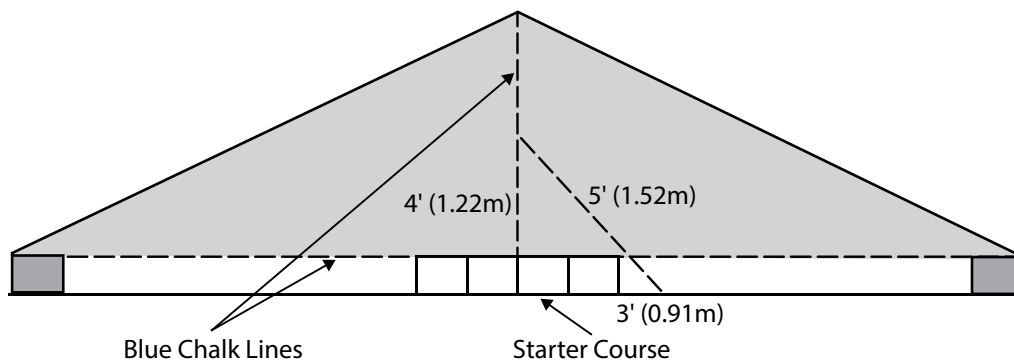

3. One method of starting on a hip roof is to locate the centre of the roof area to be covered. From both ends, position starter pieces and snap a horizontal line from the tops of the starters between these two points. Next snap a vertical perpendicular line. This can be done easily by marking 3ft (0.91m) along the eave, then where 4ft (1.22m) and 5ft (1.52m) intersect will form a perpendicular line. As long as the ratio 3:4:5 stays the same this will hold true, for example, 21:28:35. More horizontal and vertical lines may be snapped to ensure the roof slates will stay true and plumb throughout installation. Begin by placing an eaves slate on the right and left side of the vertical line maintaining a 0.25" (6mm) spacing and continue to both ends.
4. The eaves course should overhang a maximum of 2" (50mm) at the eave.
5. Begin the first course. With a full slate, align centre locator line of the slate directly over the vertical blue chalk line. Continue to both ends, maintaining the 0.25" (6mm) spacing between slates. (See diagram below.)

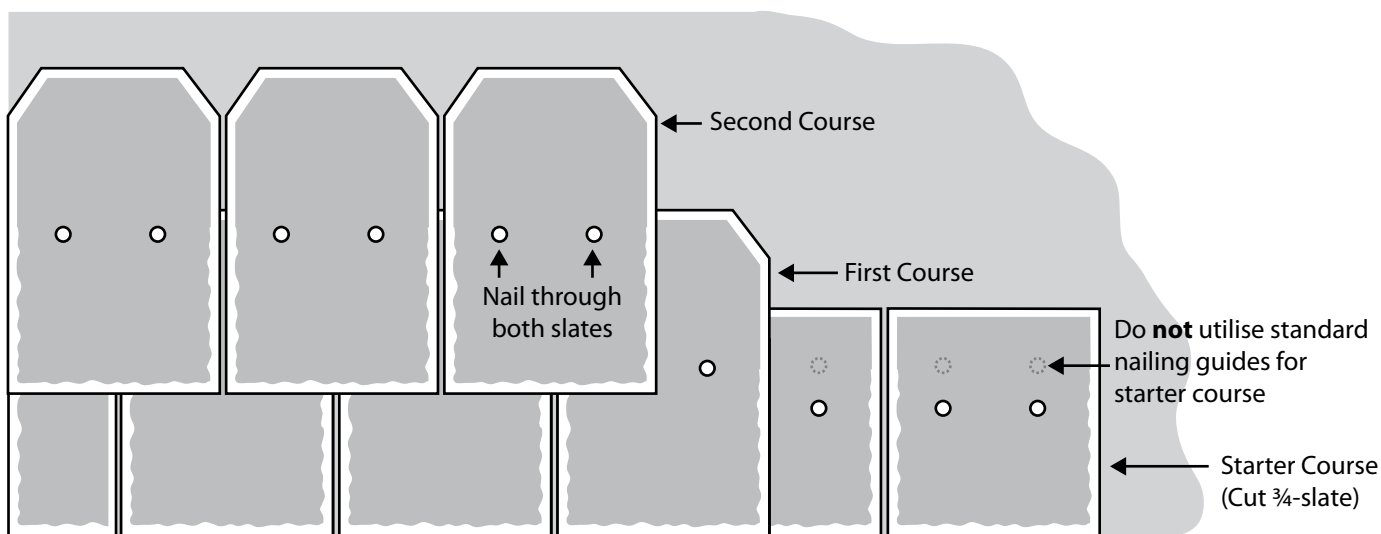

6. After installing the underlay or membrane and before installing the TapcoSlate, clean the surface of debris and dirt. Foreign particles shall be cleaned and removed from interlocking areas to ensure proper seating of the product and to prevent moisture intrusion and ice damming. All roof penetrations shall be properly flashed and secured into position with deck and underlay or membrane fasteners properly driven and not protruding prior to installing TapcoSlate roofing products.
 - a) Full slates can be cut into $\frac{3}{4}$, approximately 12" (305mm), to be used on the starter course, and at the ridge if necessary.
 - b) These eaves or starter slates will be used as the first row at the eave of the roof.
 - c) To create the offset from course-to-course, use the centre mark provided on each slate and cut the slate lengthwise. This ensures that the nail holes are covered with the next course of slates and no through-joints are exposed to the deck.
 - d) Strike the chalk lines horizontally, at the exposure level desired, to ensure that the slates are installed straight and uniform. Vertical chalk lines will help maintain consistency in the key-ways.
 - e) Spacer tabs are provided on each slate to ensure consistent spacing between slates.
 - f) There shall be no through-joints from the roof surface to the underlay or membrane.

7. Each slate shall be fastened with a minimum of two galvanised roofing fasteners. The fasteners must be a minimum of 1.2" (30mm) long and 1/8" (3mm) in diameter with a 3/8" (10mm) diameter head.
 - g) It is required that the fasteners be placed within the two nailing targets on each slate. Flatten slate then fasten. Fastener must penetrate decking at least 23/32" (18mm).
 - h) Caution should be taken where the underside of the roof decking is exposed to view, such as in an overhanging eave, where the nails should be long enough to penetrate the roof decking but not so long that they may be driven through the decking.
8. Continue the second course with a full standard slate set back from the course below, the finished edge facing the gable edge. Align the full roof slate between the centreline locators from the lower course. Next, adjust the roof slate up or down to align the desired exposure lines with the top edge of the lower course. (See diagram at right, and roof pitch table information on page 4 for which exposure line to use.)

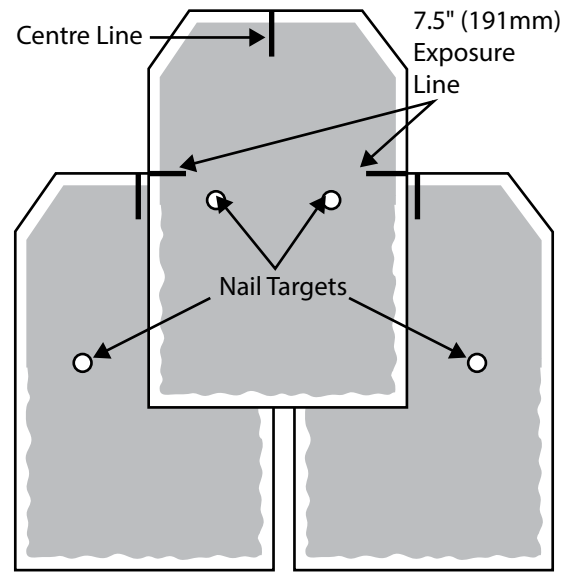

Felt and Batten Roof

The following instructions are just a guide, and standard roofing procedures should be applied. Apart from the lightness and ease-of-use that TapcoSlate affords, there is very little difference between it and standard slate in batten roof application. For felt and batten roofs, start by fixing battens – minimum size of 2" (50mm) by 1" (25mm) treated battens – over underlay to required gauge. The first course and eaves (starter) course should oversail the fascia by at least 1 1/2" (38mm), so the first course batten should be placed approximately 7 1/2" (190mm) centrally from the start of the roof (see diagram). A second batten should then be placed directly under the first course batten to accommodate the eaves or starter course (made from a cut 3/4-slate).

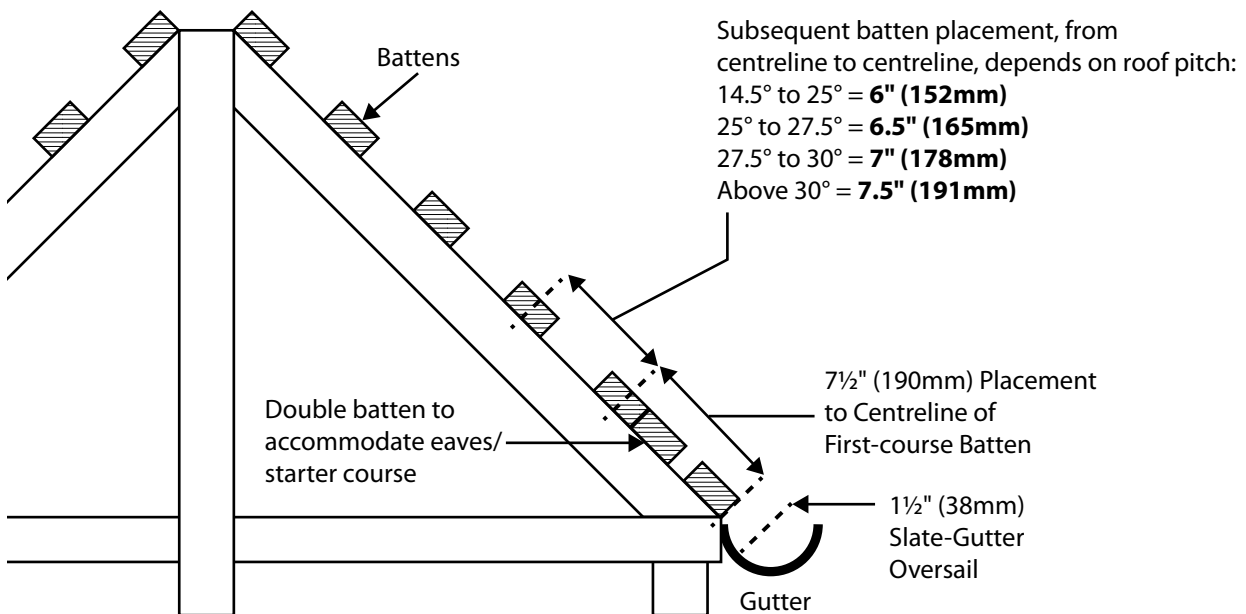

The distance from the first course batten to the second course batten, and beyond, is dependent on the roof pitch and subsequent exposure gauge settings. Please see the diagram of the TapcoSlate, and the Pitch, Gauge, and Coverage table on page 4. The diagram above also shows an approximate guide to subsequent batten placement.

The position of the top battens should then be established to ensure that the top course of slates will be covered by the ridge cap. Fix eaves, or starter course using a ¾-cut slate which can be easily cut to size from a full slate using a fine-toothed hand/circular saw or a sharp utility blade. As stated earlier, the first course and eaves (starter) course should oversail the fascia by at least 1½" (38mm). This ensures water disperses into the centre of the gutter. This must be taken into account when calculating the gauge and positioning the battens.

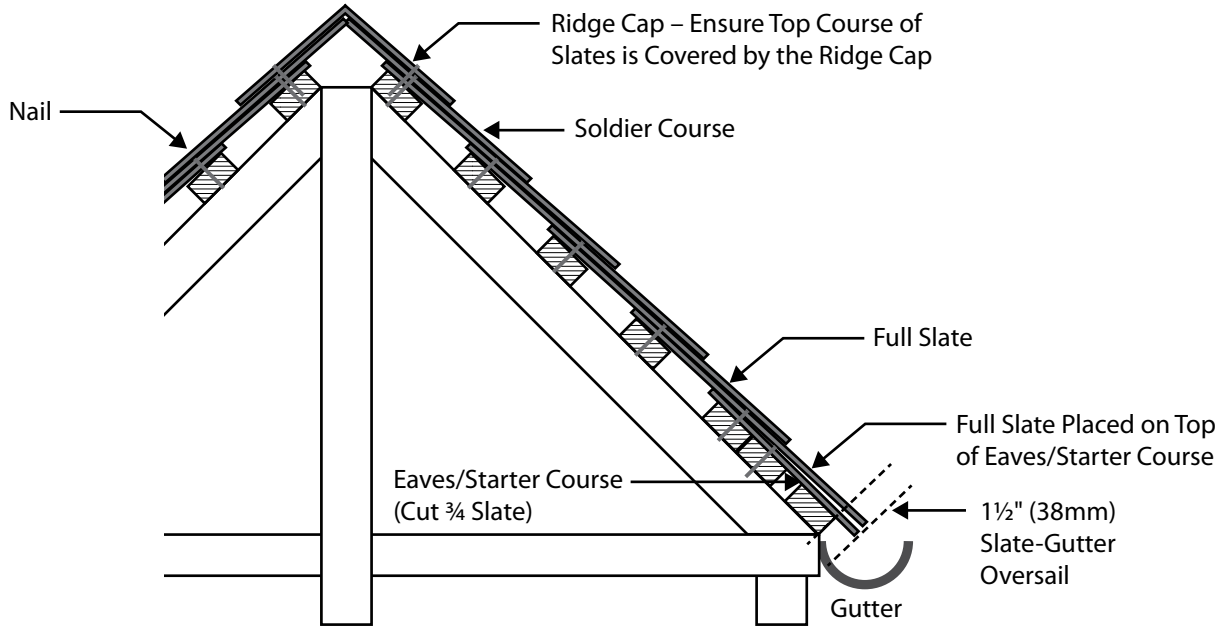

The required gauge and number of courses can then be calculated. The first course should sit on top of an eaves course. Double batten as shown in the diagram to accommodate the eaves slates.

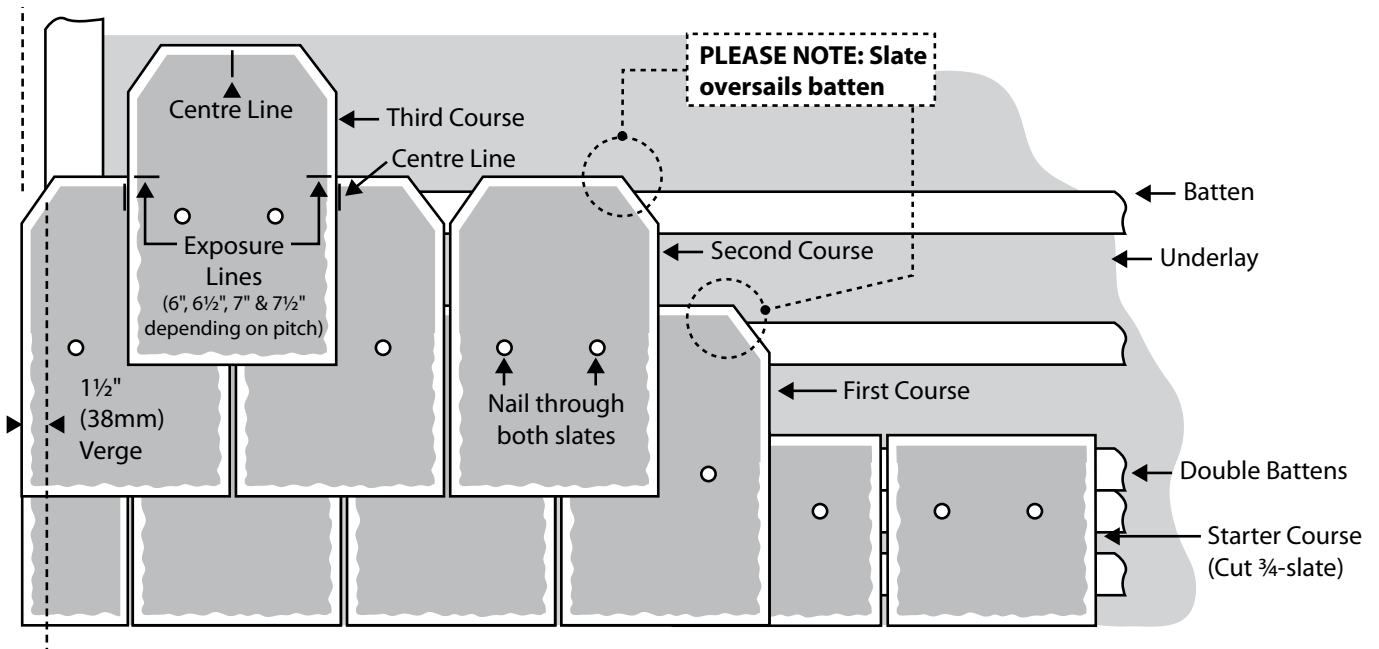

Verge slates should oversail the brickwork/barge board by 1½" (38mm), and may need to be cut to size at either end.

Lay the first course of full slates over the eaves course and fix to the second batten. Ensure that the first course and eaves course are laid "broken bond" so that the joints do not line up and the weatherproofing integrity is maintained.

Lay subsequent courses "broken bond" as illustrated. It will be necessary to cut to start and finish every other course.

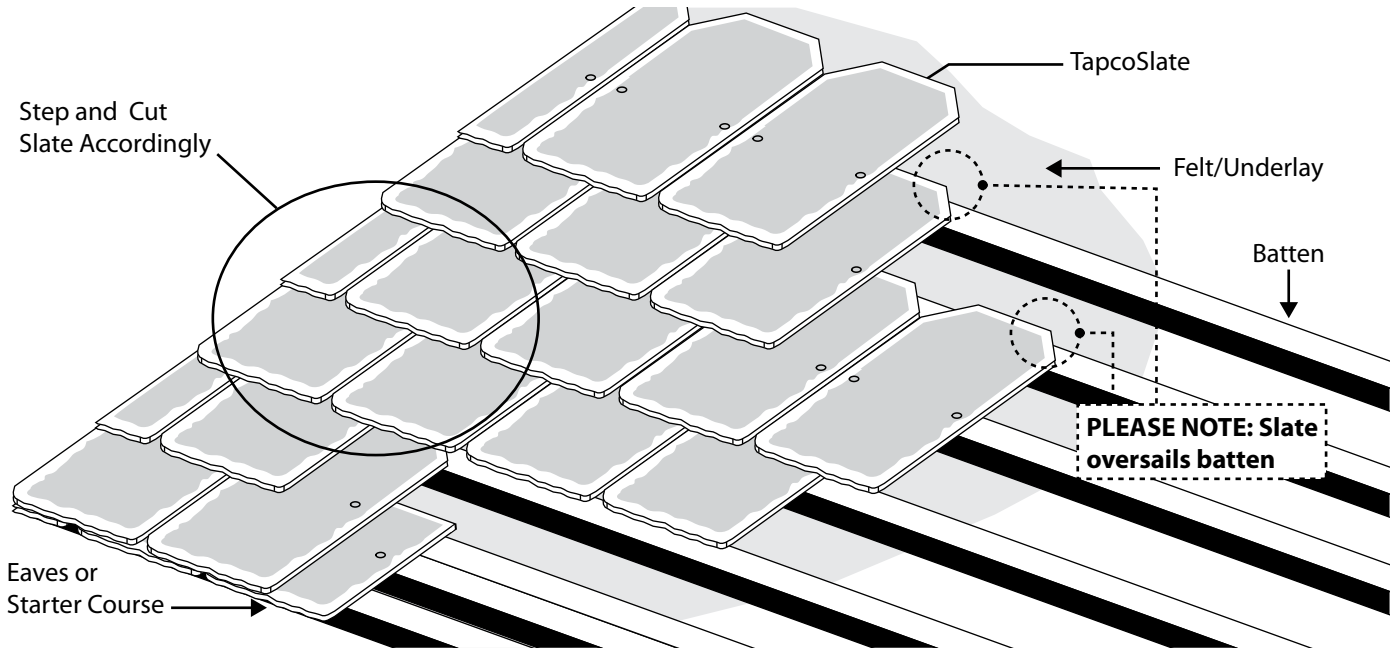

Ridge Cap Finishing

Tapco Ridge Caps should be finished by cutting a standard TapcoSlate at the end of the ridge into a triangle or diamond shape of the right size to cover the end gap. The resulting material should then be nailed in place into the end-battens and/or truss. The material can be sealed by using a good quality silicon sealant. Alternatively, the material can be joined to the Ridge Cap by using a strong epoxy glue (adhering to the manufacturers instructions). Nail heads should be disguised with coloured sealant/paint.

Standard Ridge Cap End Piece

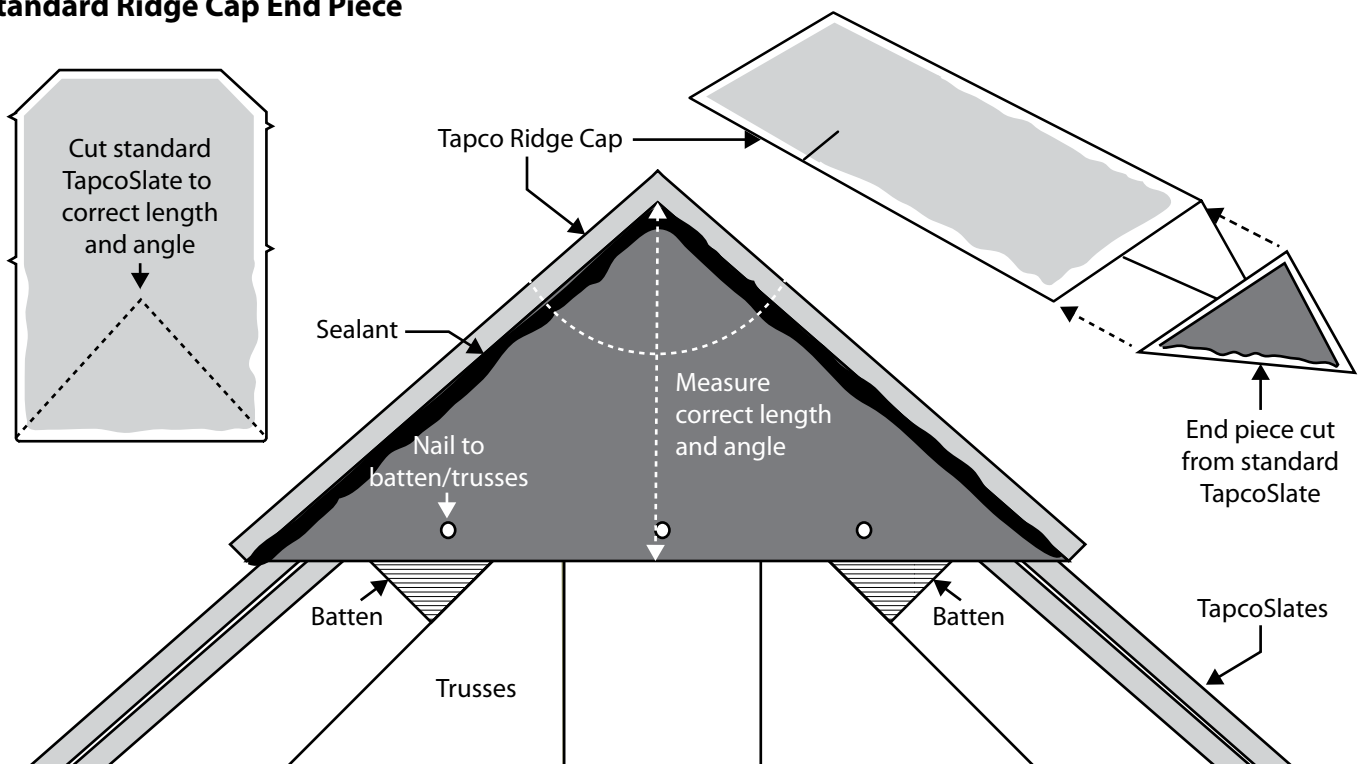

The same principle for finishing Tapco Ridge Caps can be applied to an angular finish roof by measuring the roof angle and cutting a Tapco Ridge Cap to suit. A similar measurement can be applied to a standard TapcoSlate to cut the right size and angle to cover the end hole in the Ridge Cap. Note that with an angular finish the material may have to be joined by using a strong epoxy glue (adhering to the manufacturer's instructions), unless there is enough batten/truss material to nail to.

Angled Ridge Cap End Piece

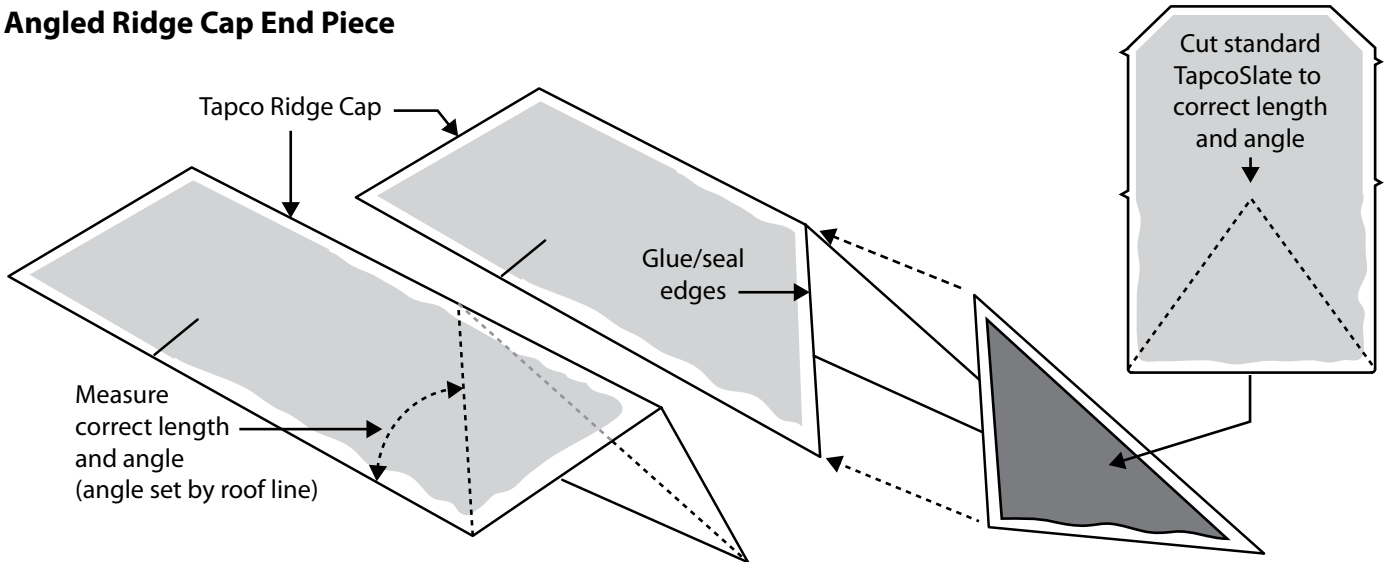

Valleys

Open Valley Design

1. Install minimum 18" (457mm) wide "W" valley or "I" seam valley.
2. Fasten the valley every 2' (0.6m) using metal cleats.
3. Slate over valley by covering flashing by a minimum of 4" (102mm). Make sure not to drive fasteners from slate into the valley flashing.

Open Valley Design

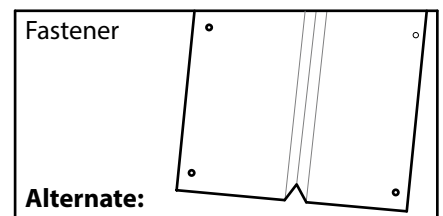
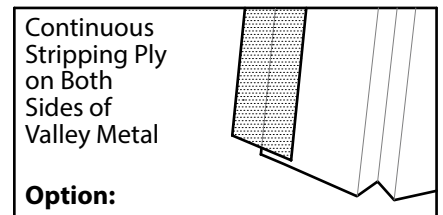
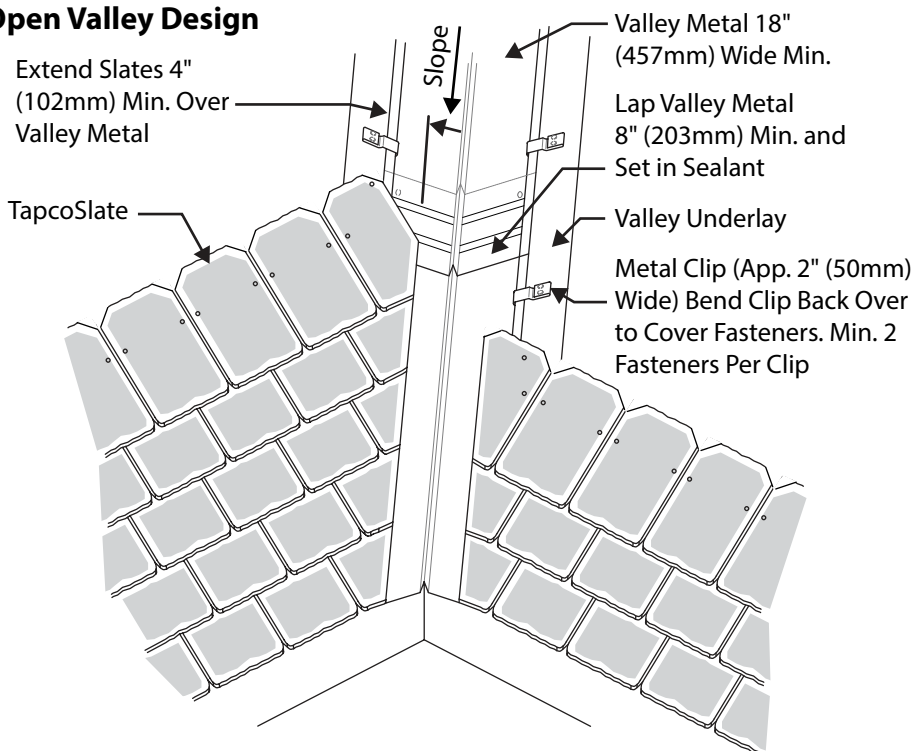

Closed Valley Design

Closed valleys are formed by laying slates tight to the valley line and placing pieces of metal under the slates. The length of the slate and the slope of the adjoining roof section determine the size of the metal sheet. Each metal sheet should extend 2" (51mm) above the top of the slate course that it will be applied to so that the sheet may be fastened directly to the roof deck. Each metal sheet should lap the sheet below by at least 3" (76mm) and set in back of the butt edge of the slate above in order to be concealed. Each metal sheet should be wide enough to extend 7" (178mm) from the centre of the valley to the roof surface. With a closed valley design, cut the slates in a straight line to fit no closer than 3/8" (10mm) against slate of adjoining roof slope.

Closed Valley Design

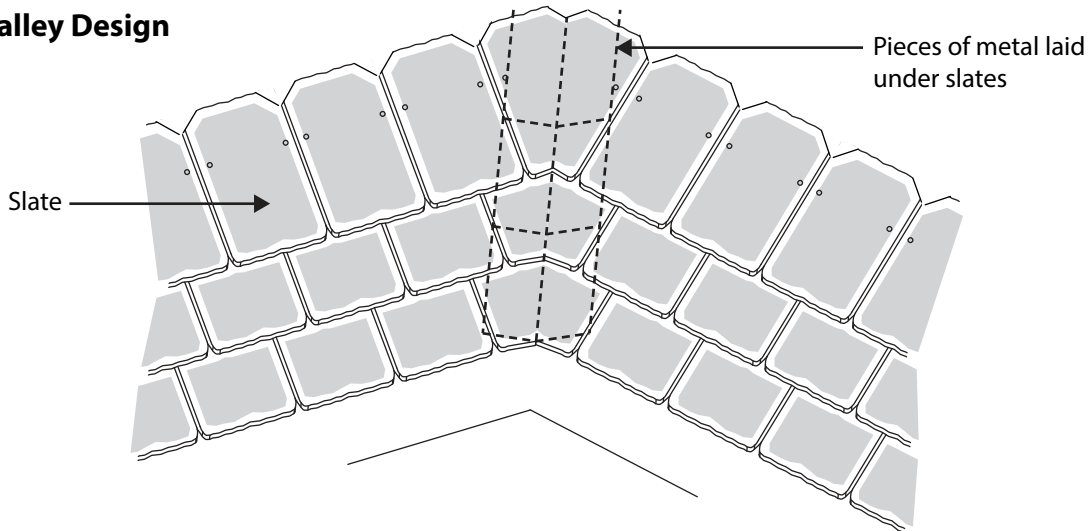

Flashings

Flashings should be used around all roof penetrations such as walls, chimneys, dormers, parapets, vent pipes, skylights, etc. Proven extended life materials are copper, lead, and stainless steel.

NOTE: When dissimilar metals are placed in contact with one another, galvanic corrosion will result which can cause electropositive metals to deteriorate. One way this can be avoided is by placing strips of sheet lead between the two metals. Tapco does not warranty metal components and accessories.

Step Flashings

Step flashings are used over or under the roof coverings and are turned up on the vertical surface. Step flashings should extend under the uppermost row of the roof slate the full depth of the roof slate or at least 4" (102mm) over the roof slate immediately below the metal. The vertical leg of the metal should be turned up a minimum of 4" (102mm) and extend 4" (102mm) on the roof slate with a 3/4" (19mm) hem. Flashings should have a minimum length of 9" (229mm) and must overlap a minimum of 2" (51mm).

Step Flashing

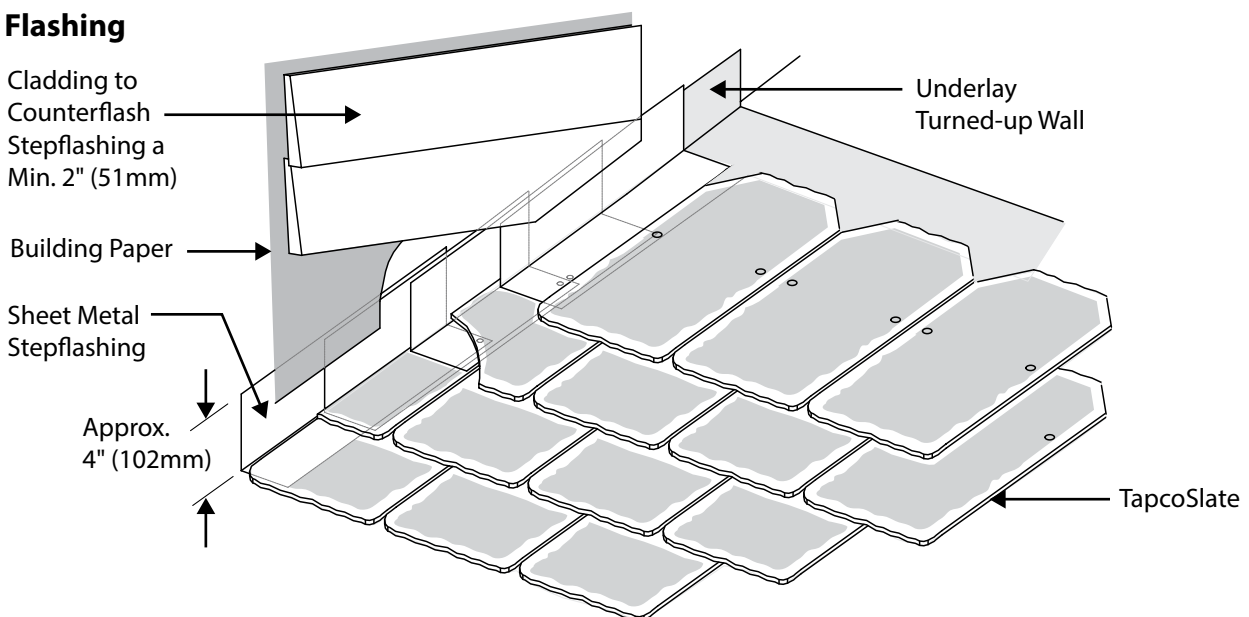

Apron (Roof to Wall) Flashing

Apron flashing is used when a roof terminates to a wall causing a course to be cut and face nailed. It is installed over the slates and behind siding or counter/cap flashing or dressed into brickwork/stonework, etc.

Apron Flashing

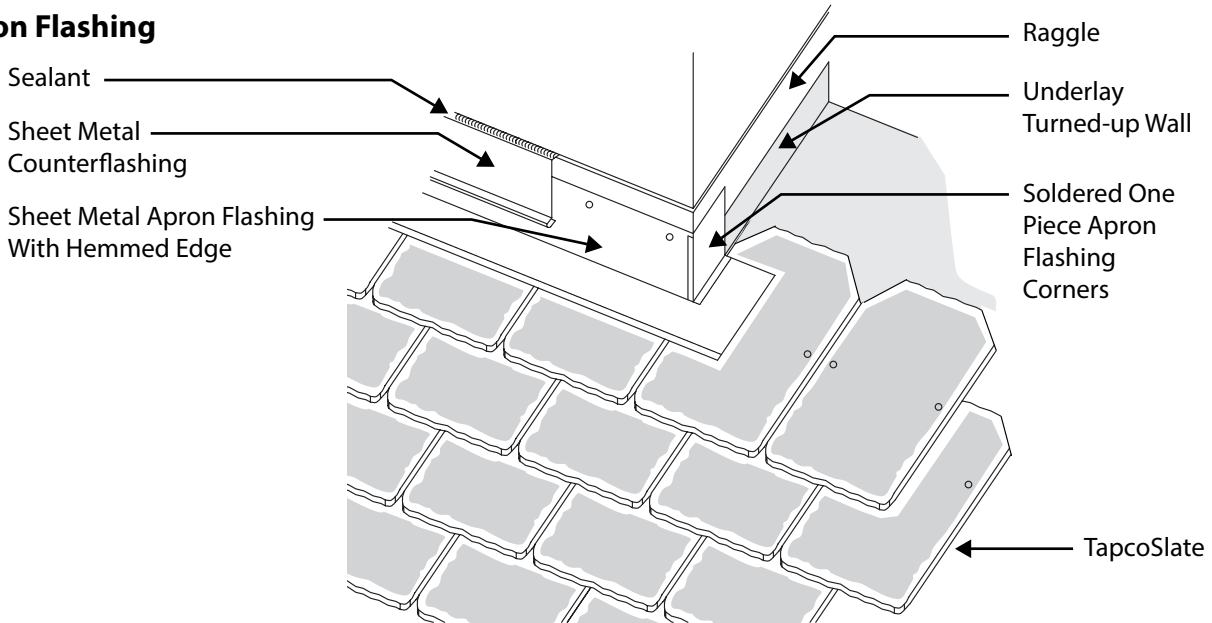

Counter Flashing

1. Cut a minimum 1" (25mm) deep reglet into the masonry material.
2. Custom bend the counter flashing to fit into the reglet.
3. Start by installing lowest piece first and work upwards for proper water runoff.
4. Fasten the counter using either expandable anchors or masonry screws.

Counter Flashing

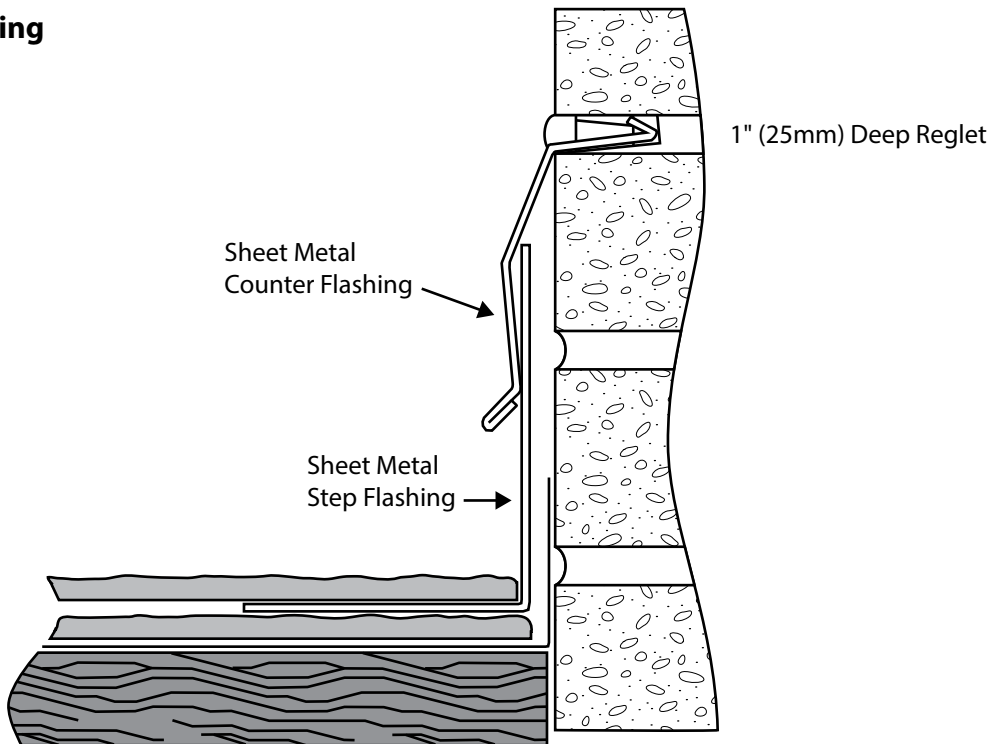

Vent Flashings

Normal type of roof vents or flashings can be used. Extended-life materials should always be used.

Soil Stack

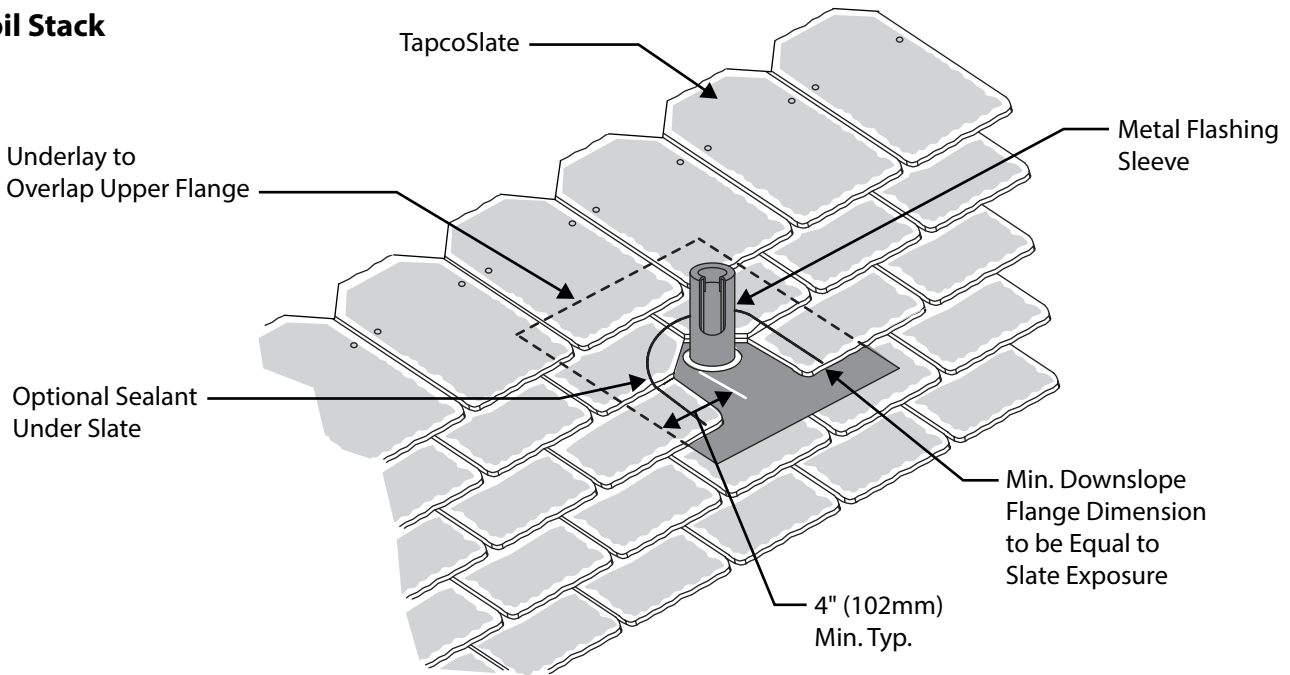

Pitch changes

TapcoSlates can be installed onto rolling roofs with a gradual pitch change. Some roof designs, however, have drastic pitch changes where the use of metal flashing is necessary.

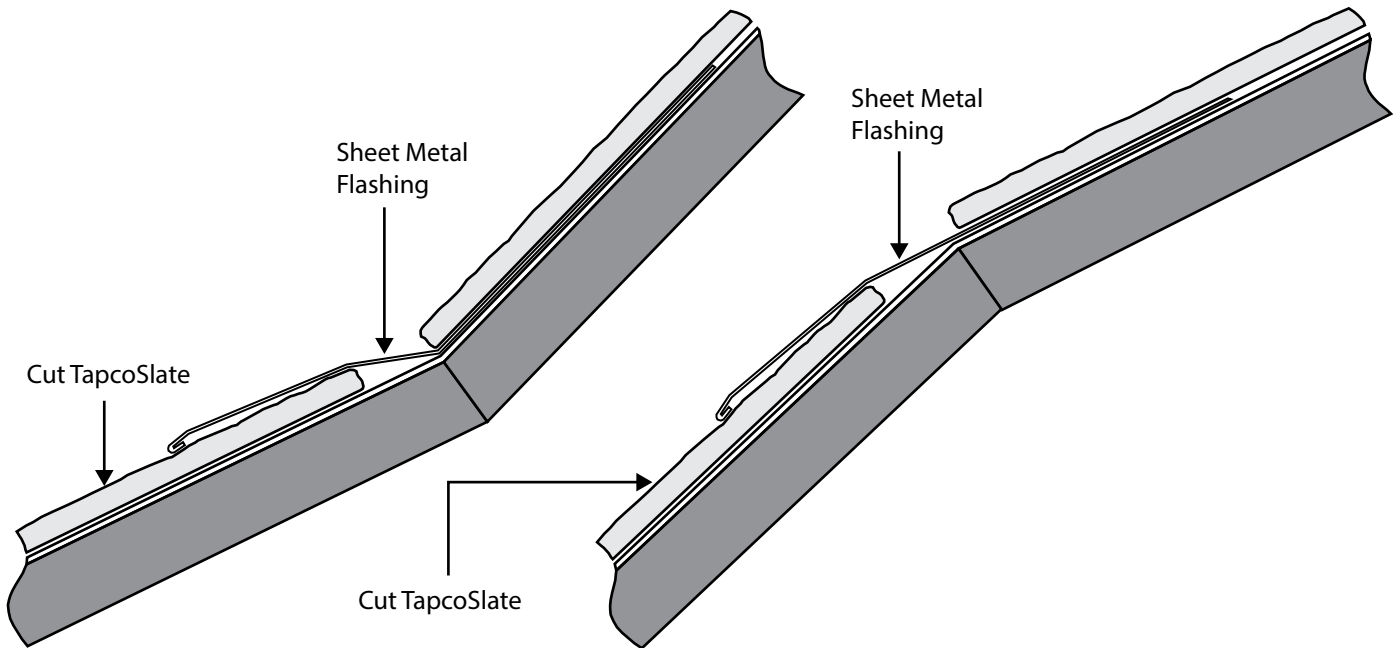

Chimney Saddles

With chimneys more than 2' (0.6m) wide it is recommended that a saddle be installed to divert water from the back of the chimney. With chimneys less than 2' (0.6m) may only require a simple pan flashing.

Pan Flashing View 1

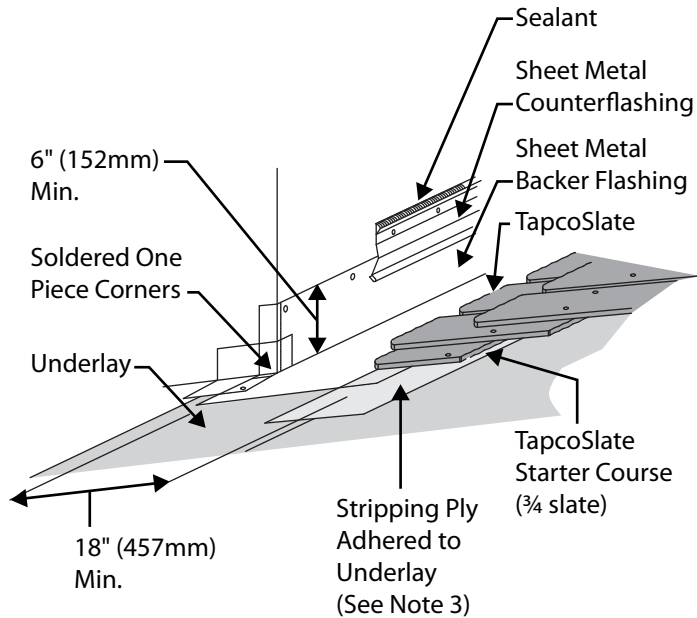

Pan Flashing View 2

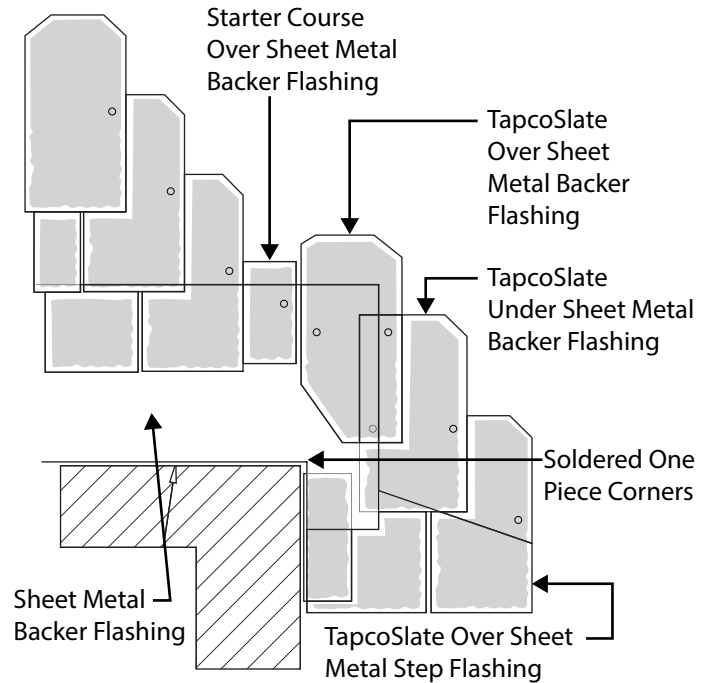

Hip & Ridge Detail on a Boarded Roof

When pre-formed hip & ridge slates are used, place nail at fastener guide targets. Fasten hip slates with 2 nails (one on each side). Maintain a 6" (152mm) exposure.

1. Hip & Ridge Slate installation requires the slate to be nailed or screwed in place.
 - a) Chalk a straight line by placing one piece of hip at the eave and one near the peak, hold the chalk line at the edge of the slate on the top and bottom pieces. This will help keep the hip straight in the event of a crooked hip.
 - b) Cover heads of fasteners with an adhesive sealant compatible with the roof slate in any case of exposure.
 - c) Preformed Ridge Slates require 6" (152mm) exposure and require 2" (51mm) length fasteners (3" (76mm) when using vent ridge).
 - d) Fastener deck penetration must be a minimum of 3/4" (19mm).
 - e) Ridge end closure can be effected by cutting a triangular section from a slate and nailing to the ridge batten, or in the case of a boarded roof, to a timber fillet.

Hip Installation on a Boarded Roof

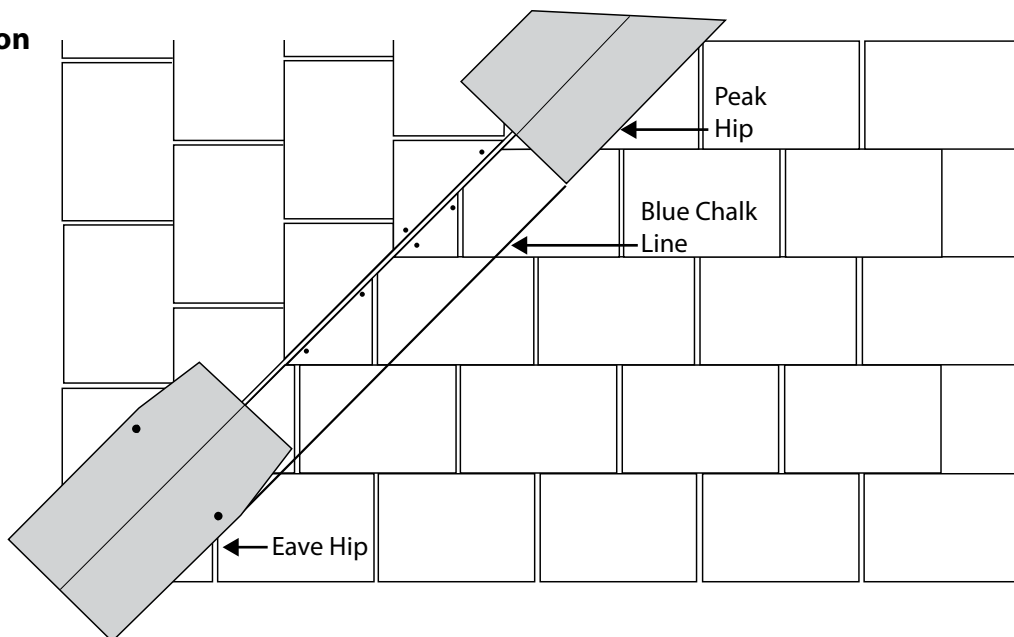

Hip & Ridge Detail on a Felt & Batten Roof

Felt & batten roofs need the addition of extra tiling battens to secure the hip tiles.

Hip Installation on a Battened Roof – Batten Layout

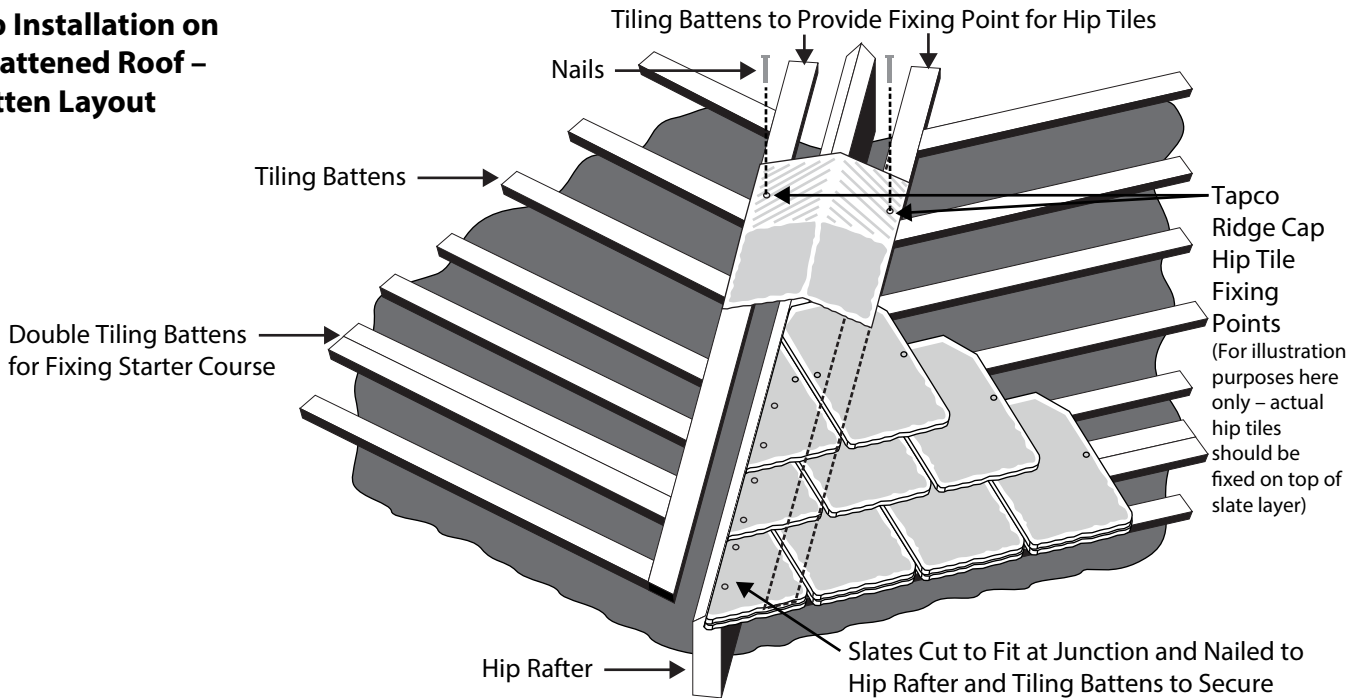

1. Cover the length of the hip with 24" (600mm) underlay from eave to ridge, overlapping the standard underlay on either side of the hip.
2. Position a hip tile in situ and mark the nailing points at the top and bottom of the hip.
3. Using these marks, secure a length of tiling batten either side of the hip to provide a fixing point for the hip tiles.
4. The slating battens should be fitted flush to these hip battens.
5. Cut slates to fit at junction.
6. Affix hip tiles using a minimum of 2" (51mm) nails or screws.
7. Finish at the eaves with a cut hip tile. Fill end with a shaped piece of standard TapcoSlate.

Hip Installation on a Battened Roof – Tile Layout

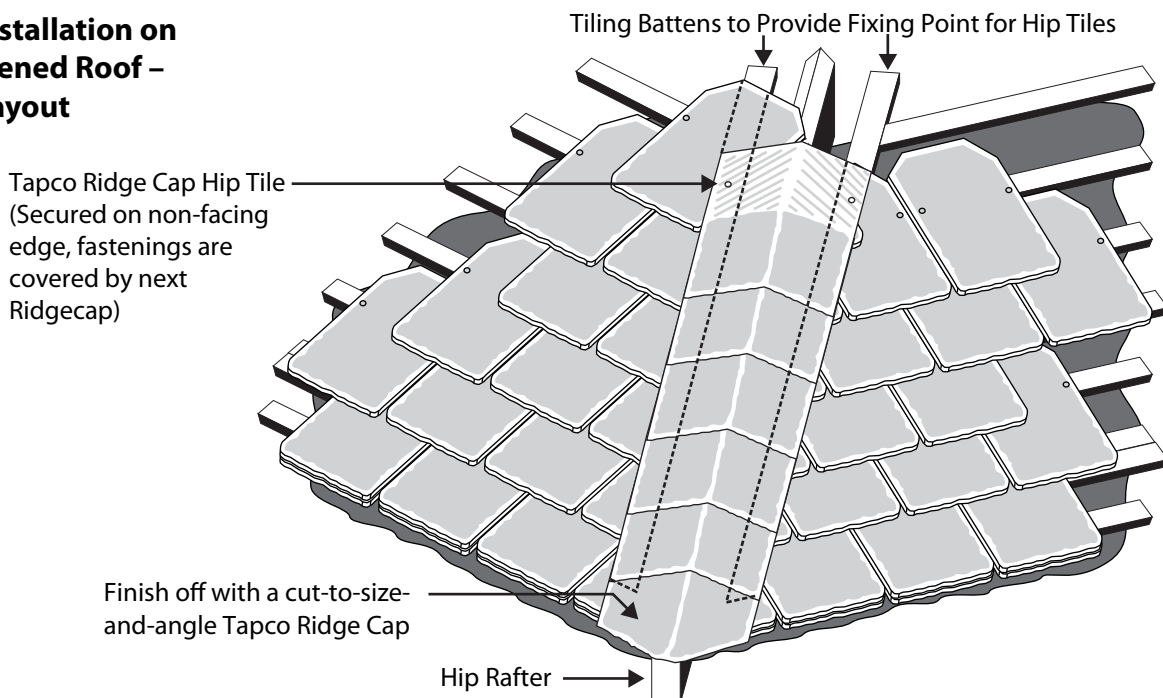

Ridge-to-Hip Intersection

When a ridge tile meets hip tiles, it is necessary to weatherproof this intersection. A lead saddle should be fitted to cover the intersection between the ridge tile and the mitred hip tiles. TapcoSlate hip tiles cut easily without splintering or cracking to effect a tidy mitred joint.

Lead Saddle Used to Weatherproof Ridge-to-Hip Intersection

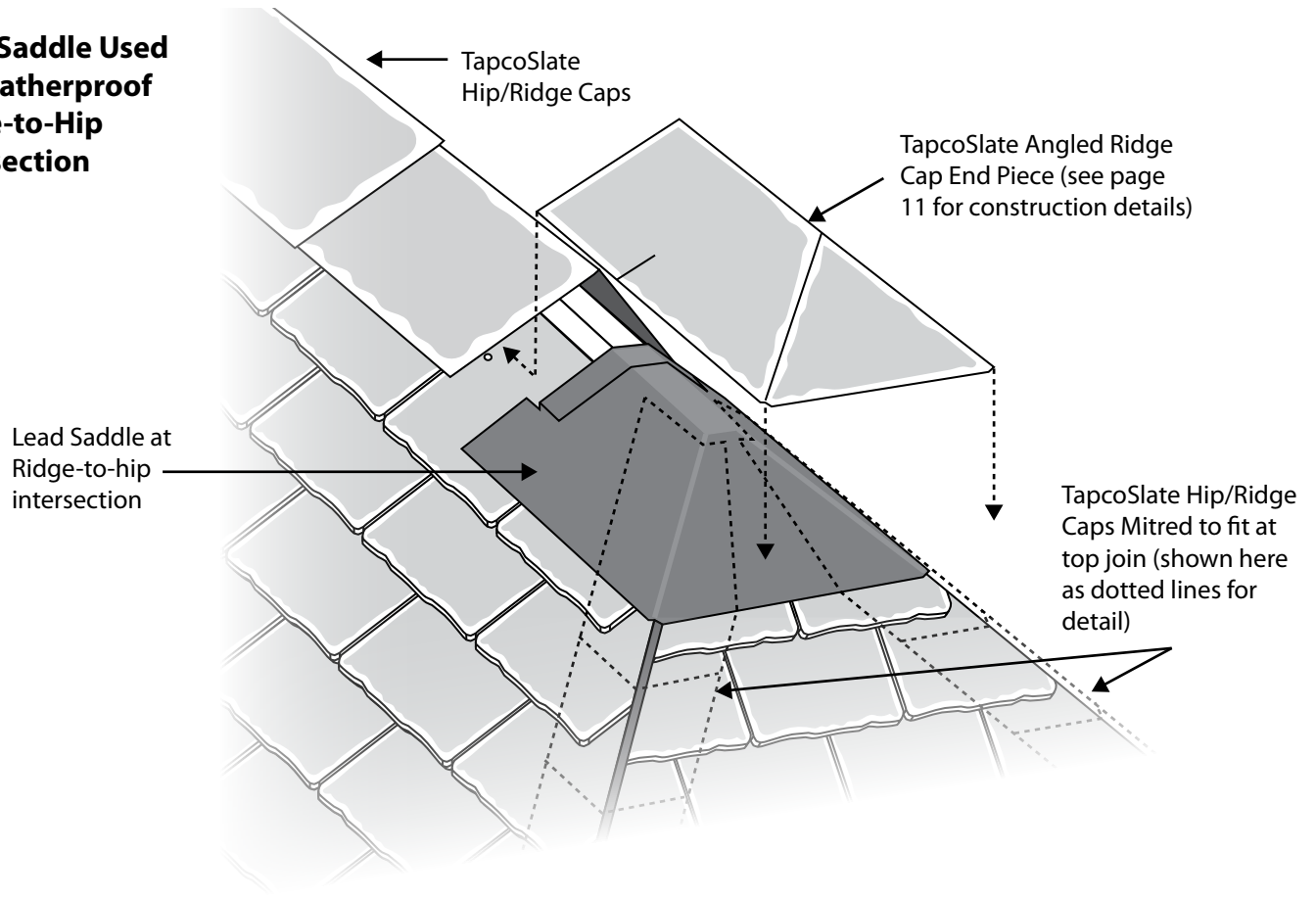

– Special Instructions –

Installation onto a Fully Boarded Roof on Pitches of 14° up to 22.5°

From time to time, certain roofing applications require installation of the slates at a lower roof pitch, (transition roofs, porch roofs, etc.), utilising a fully boarded roof, thus requiring changes to the moisture intrusion protection as it relates to the underlay and slate exposure.

For fully boarded roof decks having slopes of 14 degrees up to 22.5 degrees, a proprietary breather membrane which conforms to DIN EN 20811 Water Column should be used. Slate exposure must be at 6" (152mm) in order for the Tapco warranty to remain in effect. The Deck should be a minimum 0.7" (18mm) OSB.

Tapco recommendations do not supersede local building regulation requirements, which should always be followed.

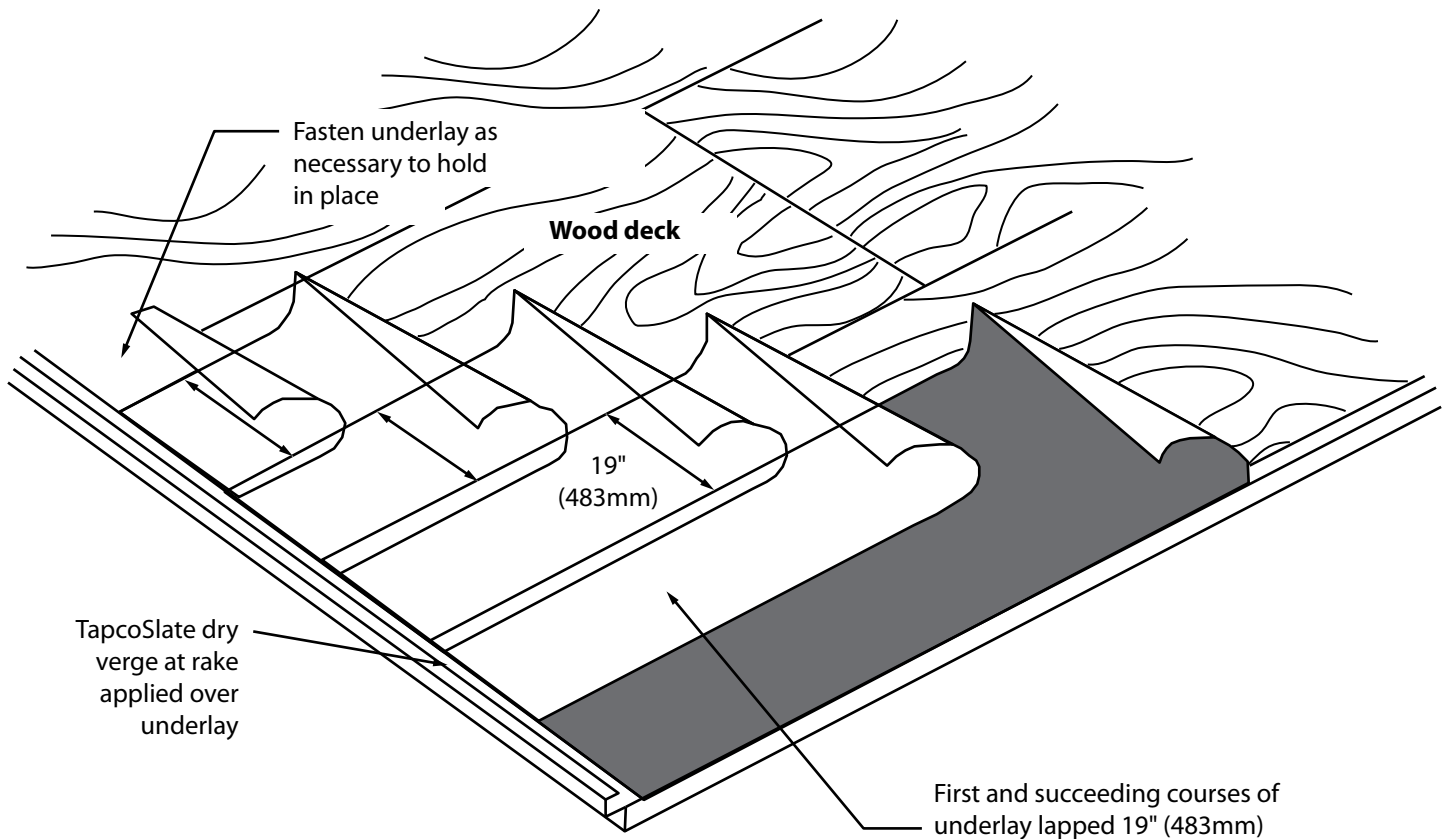

Double Layer of Underlay

Installation in Exceptionally High Wind Areas

TapcoSlates are tested for resistance to wind driven rain/wind uplift, as follows:

- Miami Dade TAS-100: (110 mph wind-driven rain). No water infiltration through sheathing. No slate cracked, split or lifted.

There are certain areas, particularly on west-facing coasts and exposed islands, where wind speeds can exceed this level, and in order to reduce the risk of uplift, the following installation instructions should be followed:

1. TapcoSlates should be fixed directly to a solid substrate, such as sarking board, OSB or weather-grade ply.
2. The maximum overlap – slates set at the 6" (152mm) gauge – should be used.
3. Standard copper roofing rivets should be installed: a hole is drilled in the overlapping or top slate, and a rivet is slid up between the gap in the two bottom slates (see diagram below). The rivet should be put in a position where it can be inserted through the hole and bent over. After a length of time the rivets will naturally blend in with the slate.

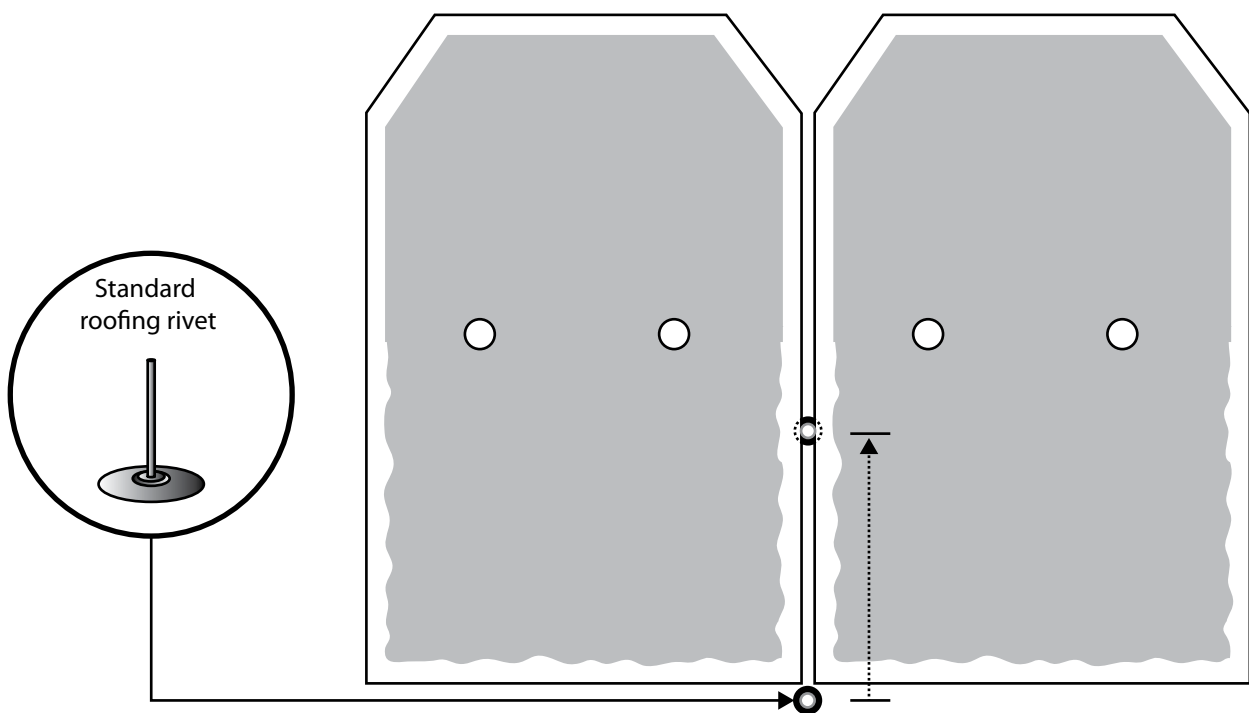

Standard roofing rivet used on 2nd row upwards of Slates. Rivet base placed in between and underneath TapcoSlates, then slid upwards to the desired location. Rivet stem should be protruding upwards.

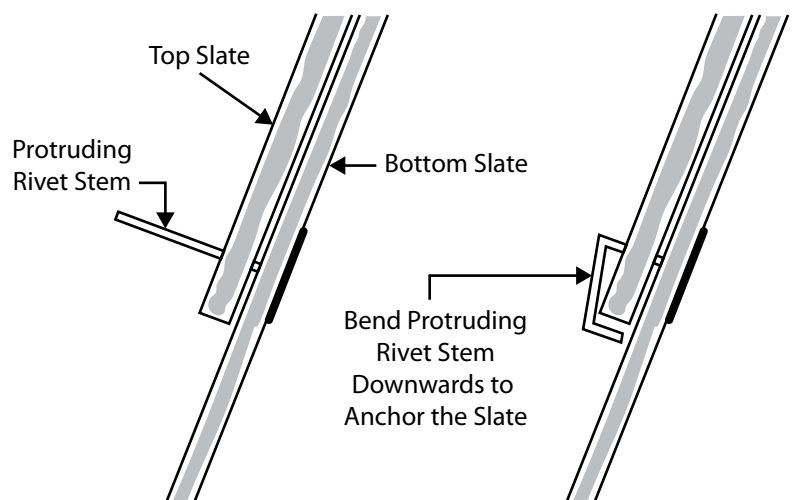
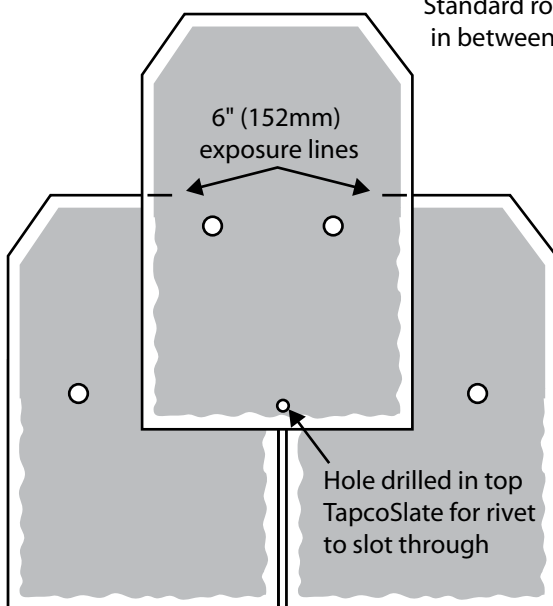

- Ventilation: RidgeMaster/HipMaster -

RidgeMaster Plus & HipMaster Installation Guidelines

We recommend RidgeMaster Plus 11" (279mm) to meet your ridge ventilation requirements and HipMaster 11" for your hip ventilation requirements, both products can be installed on roof pitches from 14 to 45 degrees. Make sure to follow the steps below when installing TapcoSlate and RidgeMaster Plus/HipMaster:

1. Cut a 1" (25mm) opening in the ridge of the roof, end all cuts 12" (305mm) from outside walls, chimneys, ridge corners or hip joints.
2. Install slates up to the opening.
3. Fold felt over last course of slates or install metal J channel to prevent the infiltration of fine powder snow between keyways.
4. Install RidgeMaster Plus and HipMaster using 3" (76mm) roofing nails. RidgeMaster Plus should be installed 12" (305mm) beyond the slot opening. For best appearance install RidgeMaster Plus along the entire length of the ridge and HipMaster along the entire length of the hip.
5. Install TapcoSlate Ridge Cap pieces over RidgeMaster Plus and HipMaster, nailing in the designated nail target areas. Use 3" (76mm) long Stainless Steel nails.
6. RidgeMaster Plus and HipMaster have an overlap and an underlap end that interlock when laid end-to-end in proper orientation. This unites the 4 foot (1.22m) sections into a single structural integrated, weather tight system. Always install RidgeMaster Plus and HipMaster with overlap end on outside terminal end of ridge. You should also complete your ridge vent with factory end on the opposite terminal end of the ridge.

RidgeMaster Plus and HipMaster will provide 12.228 square inches (7889mm²) of NFVA per linear foot.

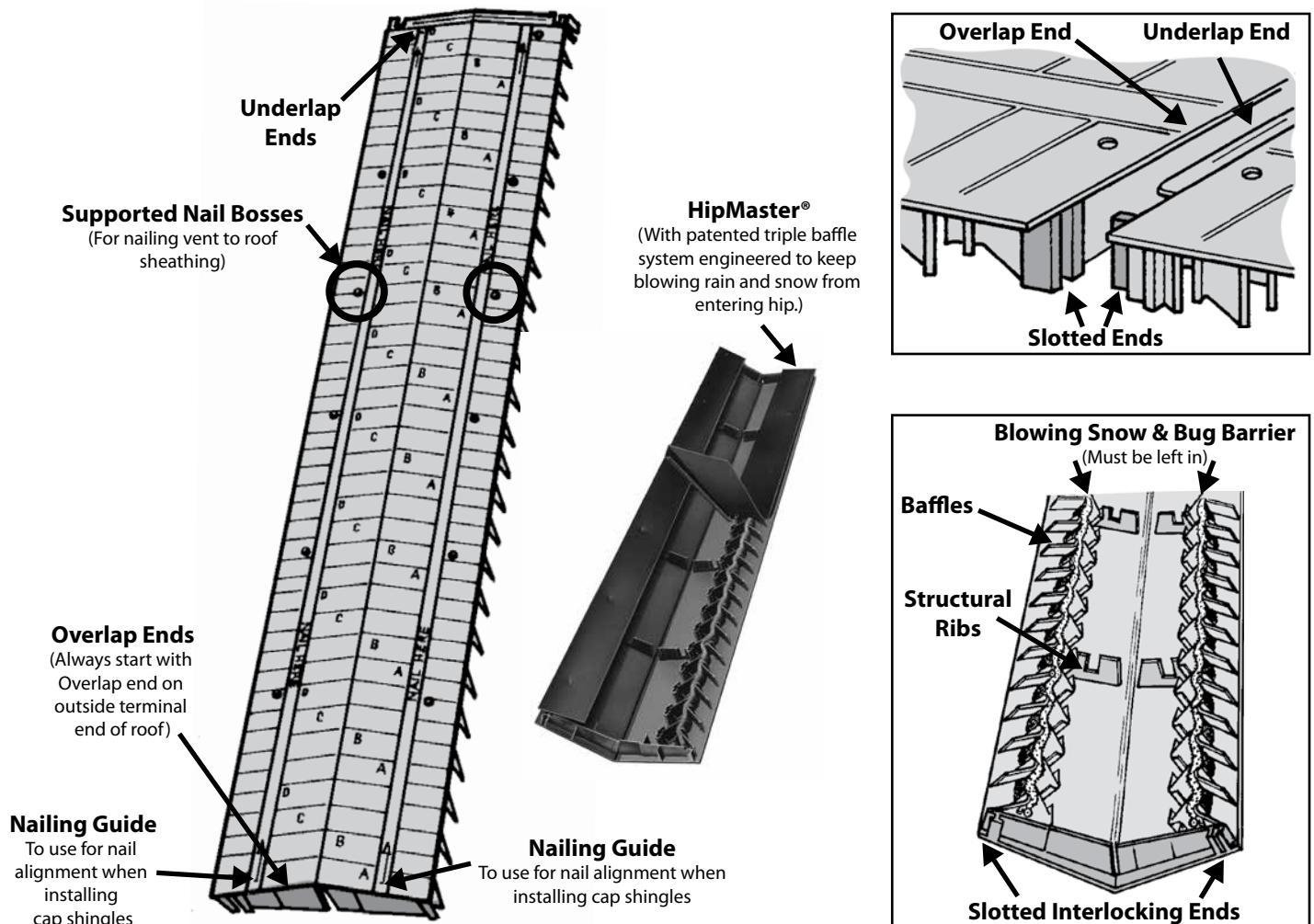

**Ridgetree Construction –
Boarded Roof**

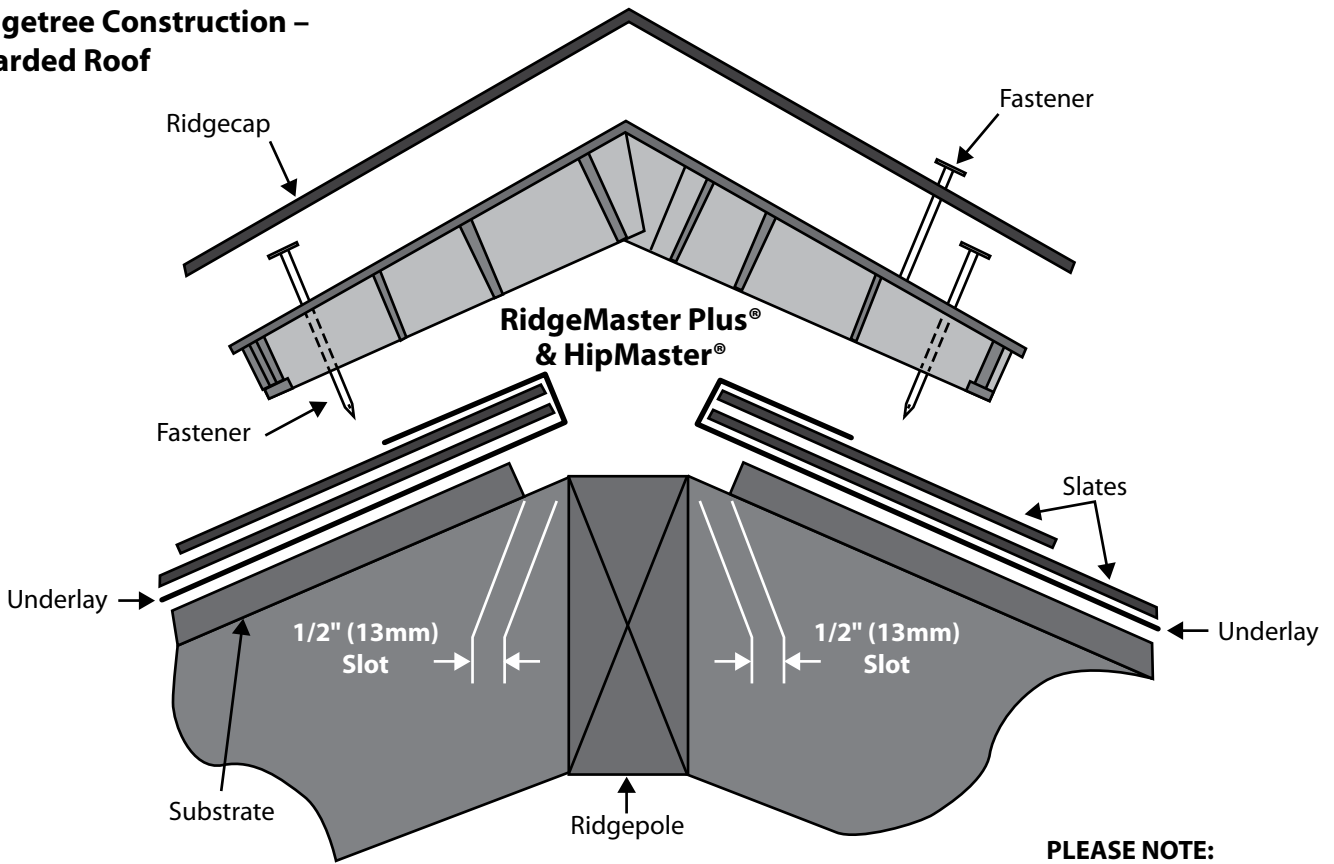

PLEASE NOTE:
RidgeMaster Plus and
HipMaster can be
installed on roof pitches
from 14 to 45 degrees.

**Truss Construction –
Boarded Roof**

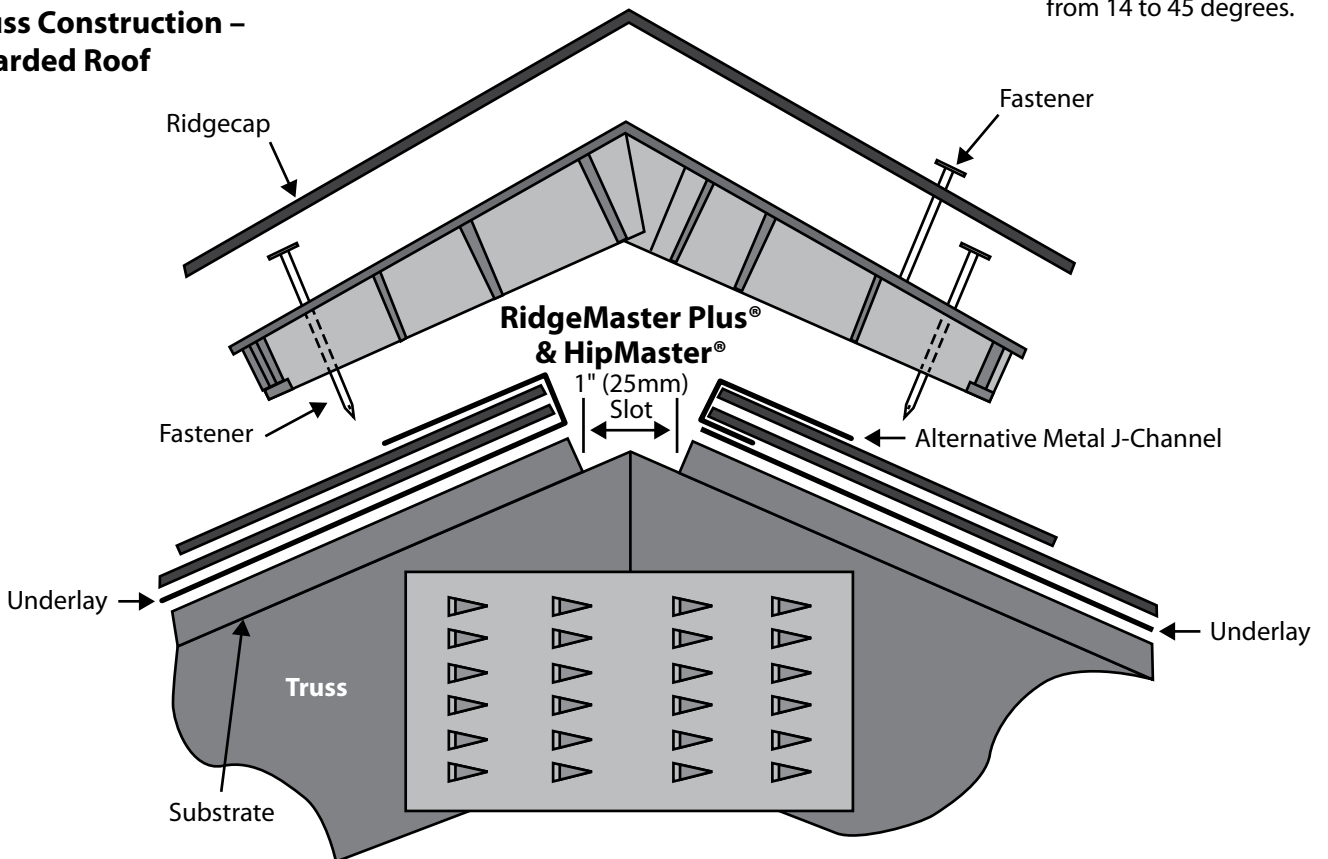

**Ridgetree Construction –
Battened Roof**

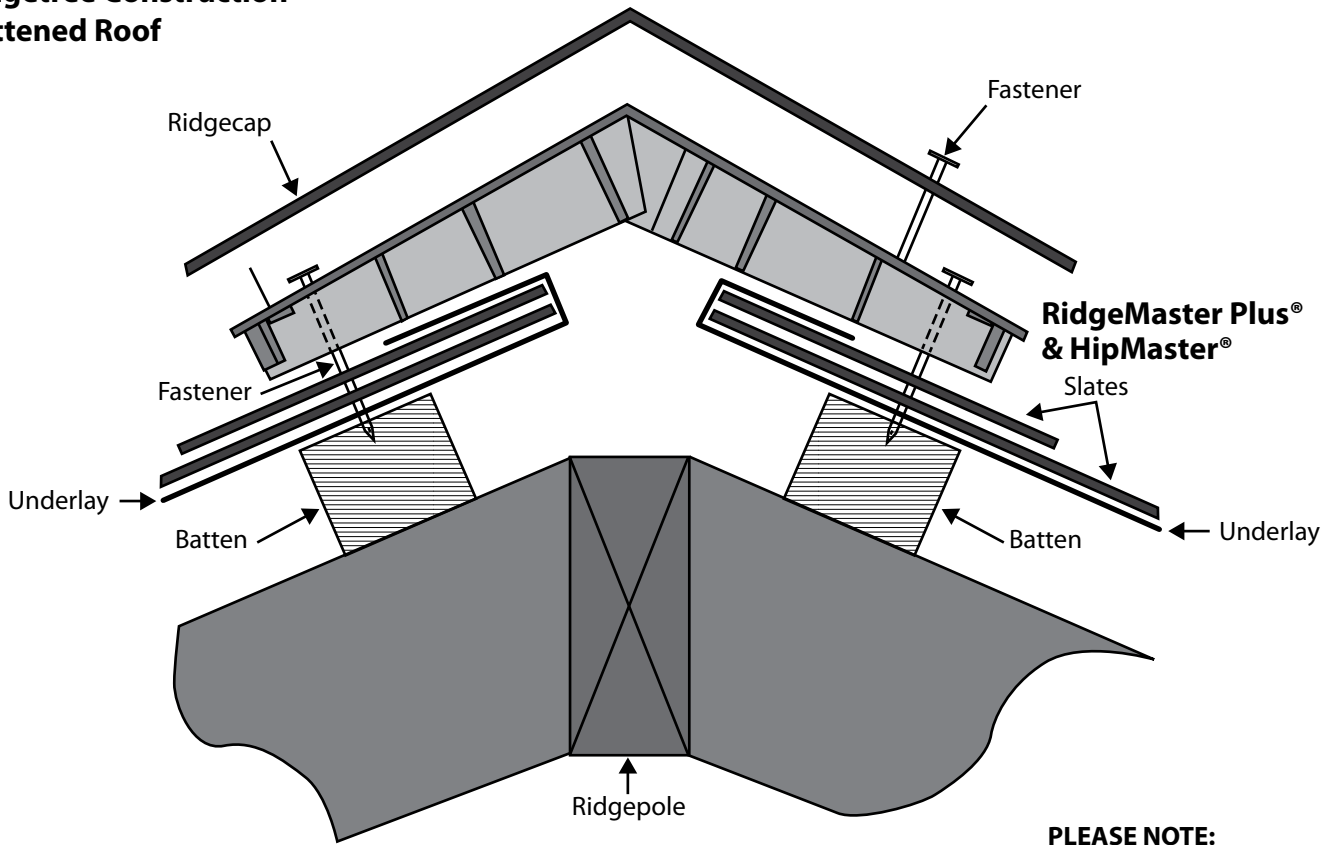

PLEASE NOTE:
RidgeMaster Plus and
HipMaster can be
installed on roof pitches
from 14 to 45 degrees.

**Truss Construction –
Battened Roof**

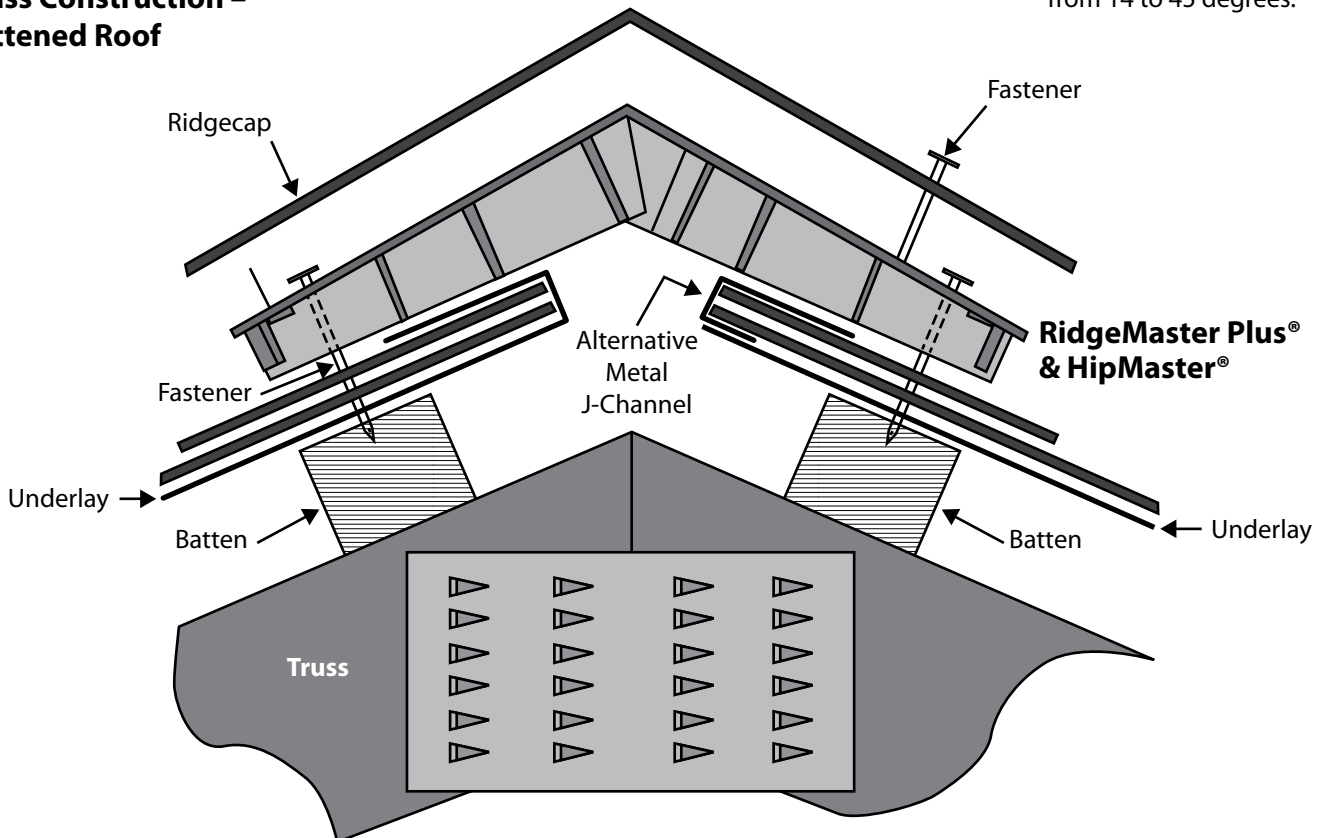

Fascia Vent – Boarded Roof

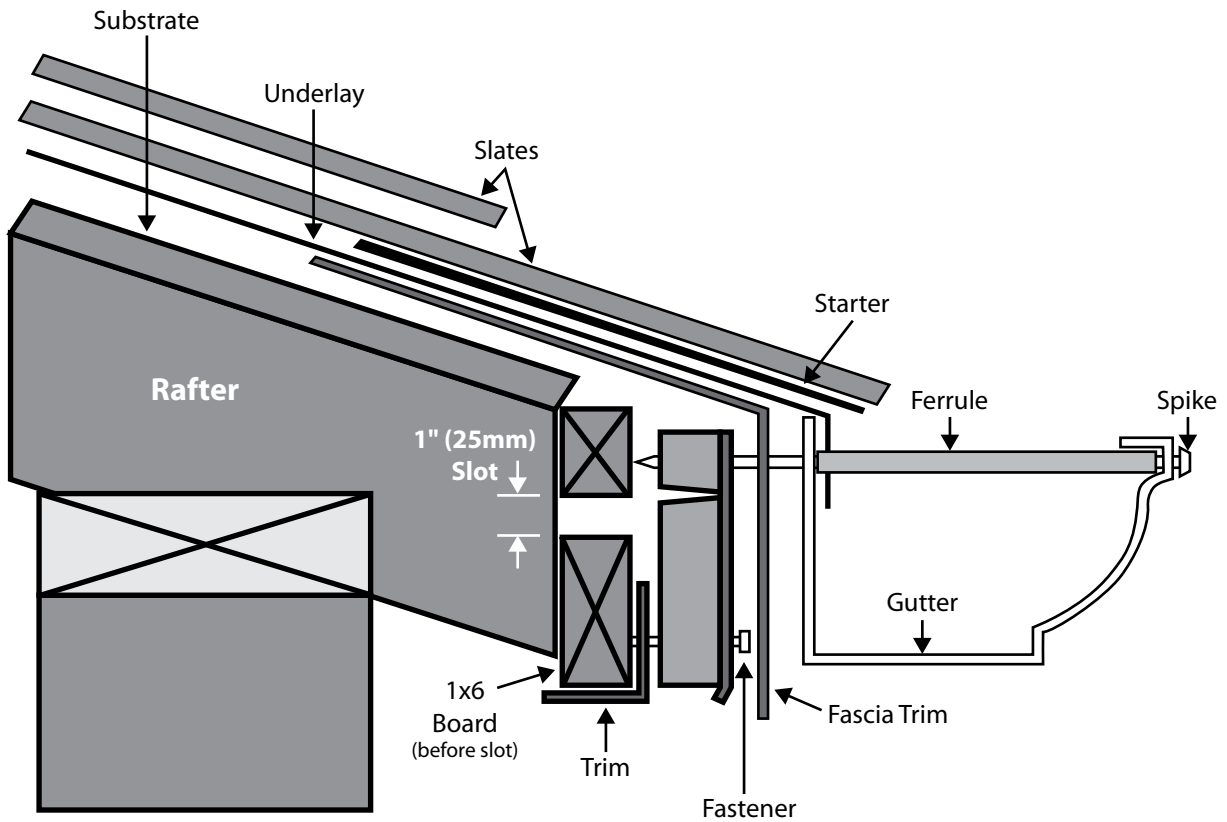

Roof to Wall/Apron Vent – Boarded Roof

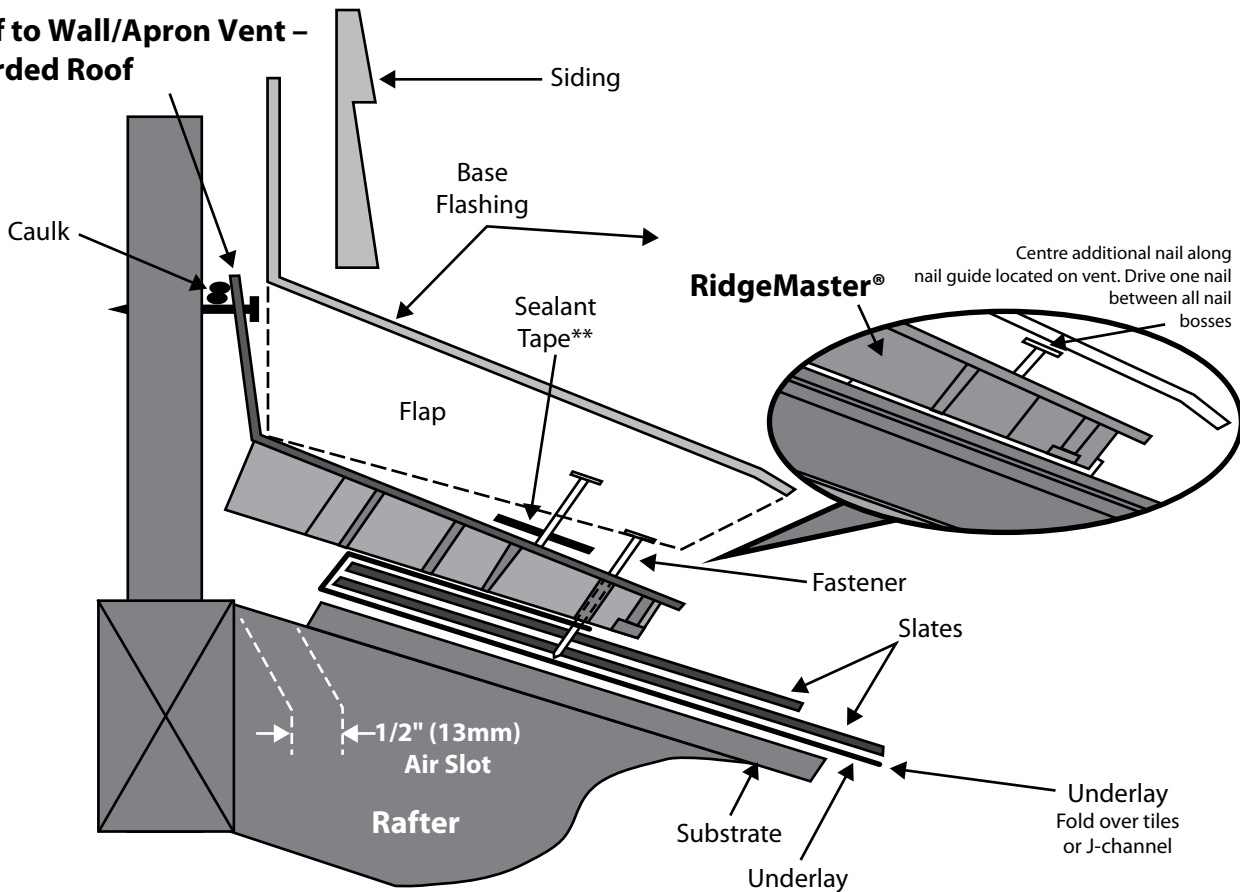

Fascia Vent – Battened Roof

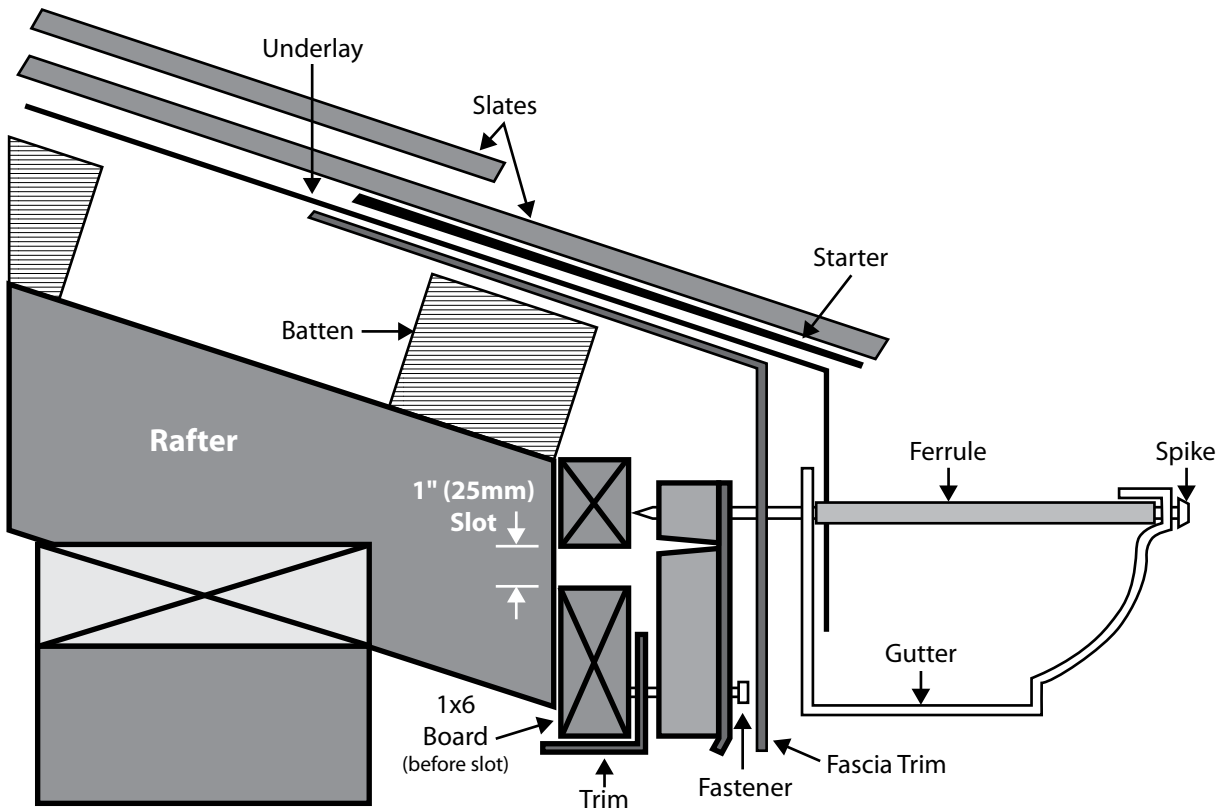

Roof to Wall/Apron Vent – Battened Roof

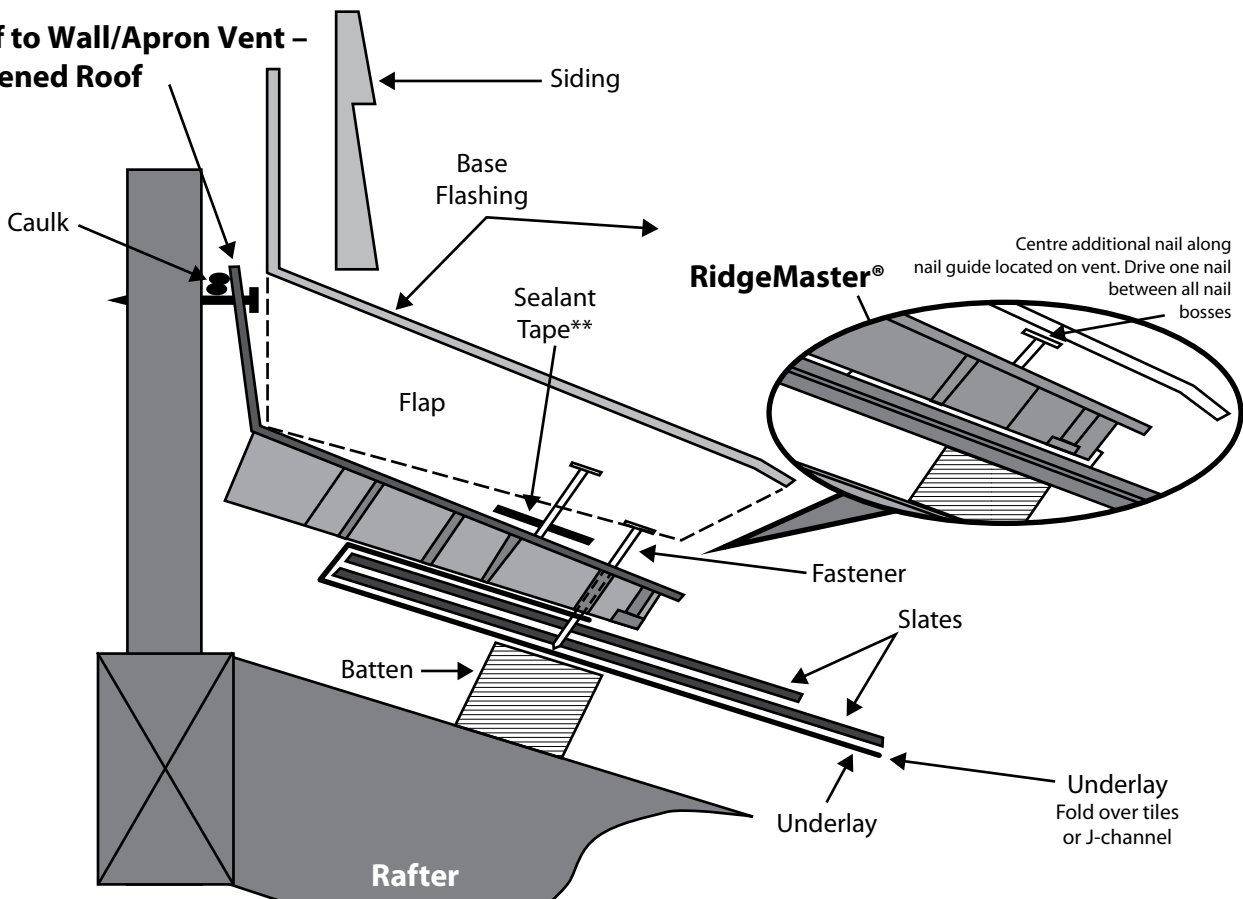

Continuous Dry Verge System

The SDV-200 Continuous Dry Verge for Slate System is designed for use with most natural and man-made slates of up to a maximum 15/64" (6mm) in thickness. Care should be taken if mechanically fixing slates thicker than this.

The Slate Dry Verge System is fitted to the top end of the battens and forms a fixing for the slate whilst covering the end of the battens.

Expansion joints are provided and the following instructions should be followed to avoid possible buckling or breaking during periods of hot or cold weather:

1. Trim ends of battens 5/64" to 5/32" (2mm to 4mm) from edge of barge board or brickwork and ensure they are securely fixed.
2. Fix first length of Dry Verge into position using suitable galvanised nails as shown in Figure 1.
3. Make sure that the end of the gutter will fit in a suitable position for discharge, and if necessary, using a fine-toothed hacksaw, trim this end of the Dry Verge to fit as required.
4. Place the next section of Dry Verge into position leaving an expansion gap of between 15/64" to 5/16" (6mm and 8mm) (as shown in Figure 2).
5. Continue fitting the Dry Verge up to the apex of the roof.
6. If a ridge tree or ridge batten is present, trim the Dry Verge using a fine-toothed hacksaw to leave a 25/64" (10mm) gap either side (as shown in Figure 4).
7. When fitting the slates into the Dry Ridge profile, care must be taken to avoid bending the profile too much with excessive force, and whilst the profile is extremely flexible, support should be provided to avoid breaking.

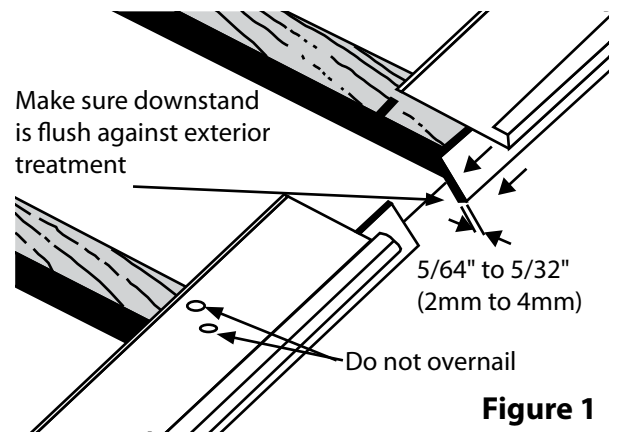

Figure 1

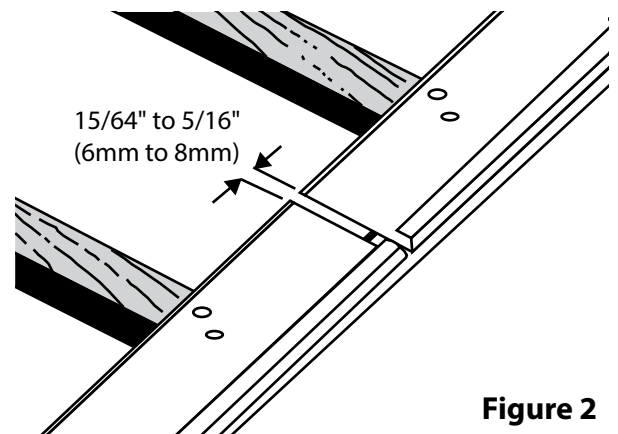

Figure 2

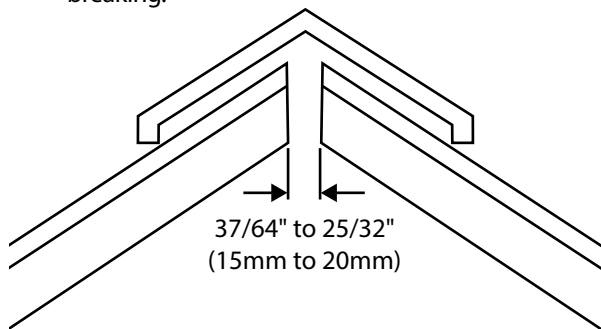

Figure 3

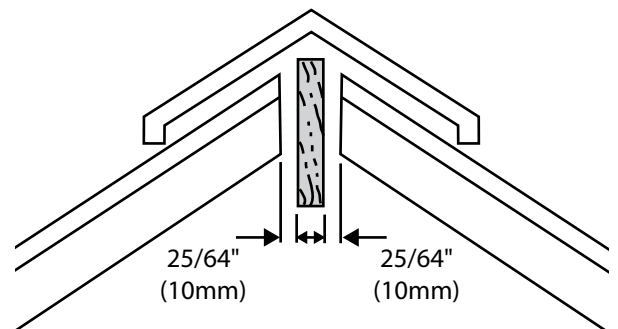
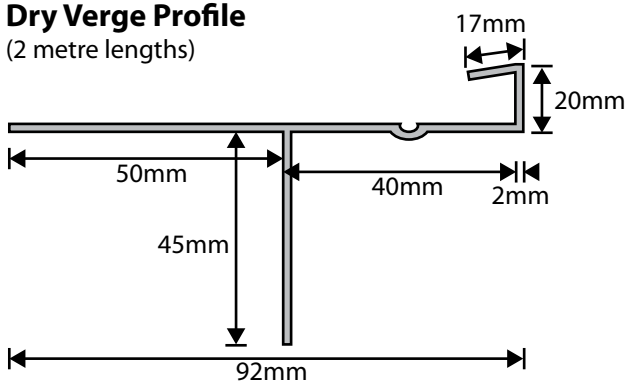
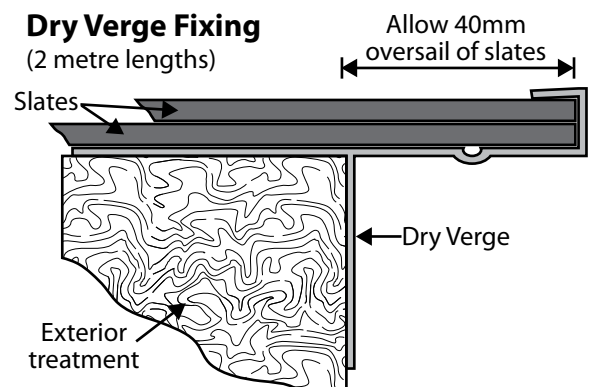

Figure 4

Dry Verge Profile (2 metre lengths)



Dry Verge Fixing (2 metre lengths)



Turret Installation

Turrets and cones need custom cut slates which change depending on the radius and pitch. They can be quite difficult to install; time and care must be taken during installation.

1. Determine the taper by chalking lines originating at the peak, extending to eave spaced 11" to 5/8" (279mm to 16mm) apart (the width of one slate).
2. Place the slate at the eave between the 2 lines, this will give you the proper taper for the first course.
3. Mark up from the top of your first slate your exposure. Repeat until you reach the top of the turret.
4. Each course will have a different taper as the pieces get smaller towards the top. You can now place a slate to each mark and determine the taper per course.
5. Be sure to pay attention to the size of the slates, If the slates get too small it may be necessary to use a larger slate and re-chalk lines at some point.
6. Make sure measurements are periodically taken from eave and peak to ensure straight courses.

Precautions

Roof slates may be slippery when wet or covered with frost. Fall protection equipment is required when working on a roof deck. The contractor may consider the use of toe boards. TapcoSlate roof slates should be stored in temperatures above 7°C and the ambient temperature of the product must be at a minimum of 7°C during installation in order to avoid webbing and/or cracking of the roof slates.

Do not leave debris under the roof slates while installing that will prevent the design of the roof slate from overlapping on the course below, thus allowing the potential for moisture build up from wind-driven rain and/or ice dams.

Use accessory products with a lifecycle as equally long-term as the roof slates.

Technical Bulletins should be reviewed and considered prior to the start of any project.

Turret Installation

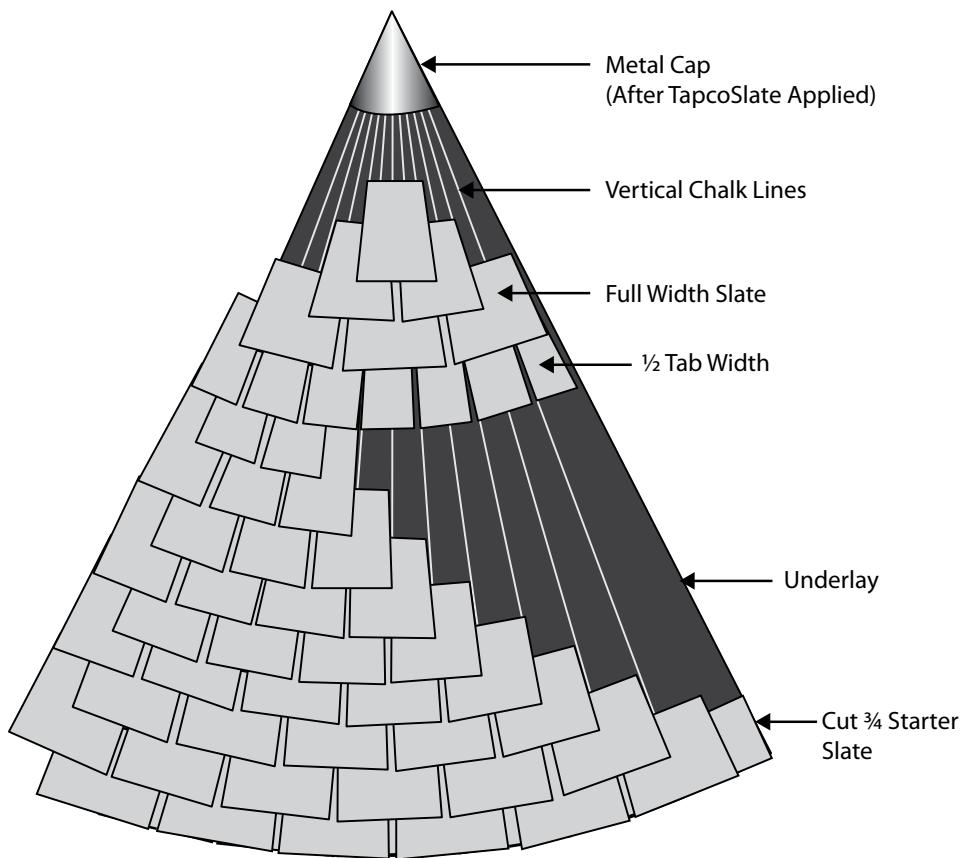

TapcoSlate Accessories

TapcoSlate accessories ensure optimum performance and aesthetics for your TapcoSlate roof from sturdy and attractive ridge and hip caps to energy-efficient ventilation products.



Ridge Caps
All Colours Available
All Fitments



RidgeMaster
Ridge Ventilation

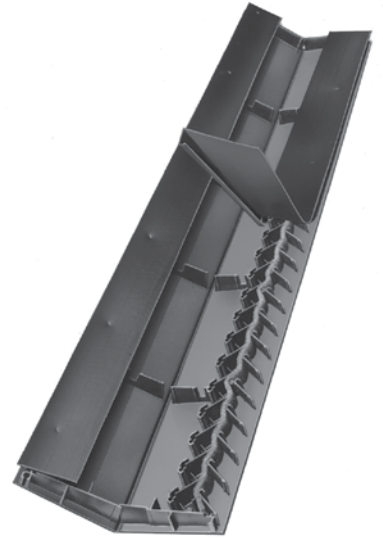

HipMaster
Hip Ventilation



Inline Vent
20°-90° Pitch Roof, 10K Airflow
Traditional Colours Available

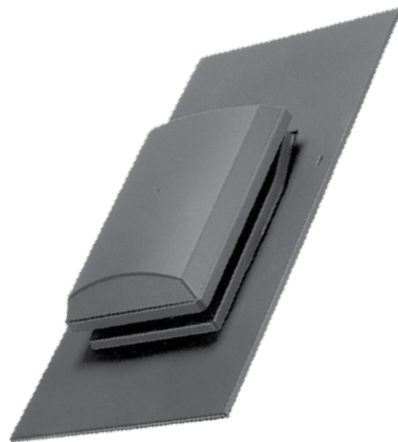

Cowl Vent
15°- 90° Pitch Roof, 10K & 20K Airflow
Traditional Colours Available



Adaptors
Round Pipe to Vent

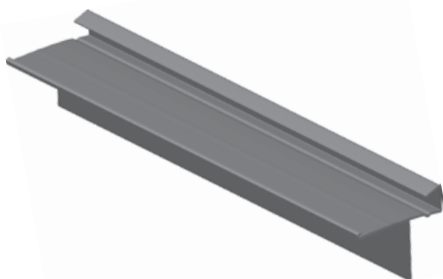

Dry Verge
Decorative Roof Edging
Available in Black



CapMaster
Eliminate Stack Vent Leaks
Available in Black



Snow Guards
Reduce Roof Snow Fall