



Rainwater systems

Design and Installation Guide



Head Office
Lenham, Maidstone, Kent ME17 2DE
Telephone: 01622 858888
Fax: 01622 858725
marley.co.uk

Scotland
Birkenshaw Industrial Estate
Uddingston, Glasgow G71 5PA
Telephone: 01698 815231
Fax: 01698 810307

Export Division
Lenham, Maidstone
Kent ME17 2DE England
Telephone: +44 (0)1622 858888
Fax: +44 (0)1622 850778

Further information
For Technical advice
please call 01622 852695
For general enquiries and details of your
nearest stockist please call the customer
services department on 01622 852585
email: marketing@marleyext.com



an *OAliaxis* company



quality 4 life



Contents

Introduction	4-7
Product Selector	8-9
Design	10-11
Product Range	
Deepflow	14
Clip-master	15-16
68 mm circular downpipe and fittings	17-18
Flowline	19
Classic	20-21
65 mm square downpipe and fittings	22-23
Miniline	24-25
Deepflow150	26
82mm circular downpipe and fittings	27
Industrial	28
110, 160 mm circular downpipe and fittings	29-30
Flat roof outlets	31
Hopper Heads	32
Ancillary items	33
Installation	36-40
General Information	41

The advantage of Marley Rainwater Systems

Marley Plumbing & Drainage offer seven different gutter profiles accompanied by five downpipe options. The product range is the culmination of over 40 years experience of producing rainwater systems. Add to this a continual product development programme, using the latest technology, materials and manufacturing processes. All products are subjected to exhaustive testing procedures to prove fitness for purpose, ease of installation and long term performance.

Marley rainwater systems are lightweight, corrosion resistant and coloured throughout the material thickness.

All products are manufactured at the Marley Plumbing and Drainage factory in Lenham, Kent. Marley rainwater goods are manufactured under a quality assurance system from unplasticised polyvinyl chloride (PVCu). Products comply with the material and performance requirements of BS 4576: Part 1: 1989 and BS EN 607: 1996.

Life⁴ – rainwater systems that stay looking better for longer

Marley have always led the way with rainwater systems; the Life⁴ range is the latest innovation.

Life⁴ gutters and downpipes:

- **look better** with high gloss levels
- **for longer** with stable colour retention levels of up to four times longer than standard PVCu rainwater systems

Marley rainwater systems perform well. However, time takes its toll on everything and inevitably, gutters fade and lose their shine over the years.

Life⁴ makes this a thing of the past.

Gutters and downpipes are normally manufactured using a process called extrusion. Life⁴ gutters are 'co-extruded'. Co-extrusion is a process by which two different materials are extruded at the same time to make one product.

Life⁴ uses a higher specification material to form a capping layer on the outside of the gutter or pipe, with standard material on the inside. This higher specification material, by its very nature is more durable.

The following Marley rainwater systems have Life⁴:

Deepflow semi-elliptical gutter, 68mm circular downpipe, Clip-master half round gutter, 68mm circular downpipe, Flowline square gutter, 65mm square downpipe, Deepflow150 high capacity semi-elliptical gutter, 82mm circular downpipe



Colour Fastness

Fully tested to BS 4576 and BS EN 607.



The Range

The choice of size and profile means that the range includes a system for almost any building or application.

Deepflow is the installers' choice as it can be installed as a notched or notchless system, according to the application and/or installer preference. It also features the Easyclip on all fittings.

To make installation easier, the gutter union and outlet have not only central screw holes but additional side fixing points. This allows easier access when using power tools, and gives added security when fixing to cellular fascia board. Deepflow is a 110mm semi-elliptical profile.

Deepflow150 is a larger version of the Deepflow profile and is ideal for small to medium commercial projects, flats and industrial applications. Deepflow150, a semi-elliptical profile, can also be installed as a notched or notchless system.

Classic is the specifiers' choice. Its original decorative Ogee shape is suited to a wide range of architectural styles. The range features injection moulded flexible gutter seals, providing reliability and ease of installation. Outlets allow connection of either square or circular downpipes and where used, Internal fascia brackets provide a continuous profile. The system boasts a very high capacity of up to 4.15 litres per second being drained by a single downpipe.

Clip-master and Flowline are practical domestic gutter systems designed for fast, easy installation. Clip-master and Flowline now feature the EasyClip on all fittings. Clip-master 112mm half round gutter is manufactured to BS 4576/BS EN 607, is very cost effective and connects to most other half round systems. Flowline 112mm rectilinear gutter is one of the largest capacity square gutter systems with 65mm outlet and is ideal for modern houses or the larger roof.

Industrial, a 150mm half round system is ideal for industrial, agricultural and commercial buildings.

Miniline is a 75mm half round system ideal for sheds, porches or greenhouses and available in three colours. See pages 10 and 11 for design guidance and 34 to 38 for installation details. Individual product details can be found from page 14 to 31.



The EASYclip

Advanced injection moulding techniques have been used to produce The Easyclip, which, uniquely, is parallel to the gutter. This in turn provides a greater degree of flexibility when making a joint.

Twin compression tabs, which are separate from the flexible part of the clip, apply downward pressure onto the gutter seal to ensure a watertight joint. The wedge shape of the underside of the Easyclip retains the gutter at the top edge and makes a positive 'click' when the joint is made.

As is sometimes necessary on site, the fittings and gutter can also be dismantled simply and quickly thanks to the new clip design. The joint comes apart by simply lifting up the clip and pulling the gutter forward.

Installation

The list of installation benefits sets the systems apart: fascia brackets have raised bars on the inside face of the bracket, which means easier installation and allows the gutter to move freely to accommodate temperature variations.

The gutter range offers a choice of two effective jointing methods according to the installers preference. All fittings have a gutter insertion line, to ensure correct installation. The two-part pipe clip and backplate allows for adjustment when fixing to the wall and the socket clip locates in the distinctive Marley socket to support the offset assembly, which ensures a positive joint is made to the gutter outlet. Downpipe offset bends can be jointed using solvent cement to provide a 'sealed' system for improved performance or to secure a long offset. The Industrial 150mm half round gutter range is available with a cost effective 110mm downpipe system specifically designed for rainwater applications. Please refer to pages 36-40 for further information.

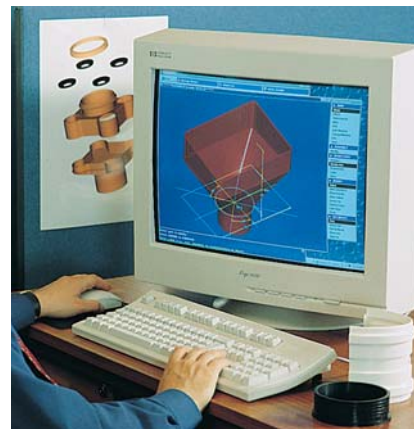

Technical advice and design guidance

A free advisory service is available to offer technical assistance regarding product and installation details. Those involved with the building industry may take advantage of design services provided by the company for customers who have made a commitment to use or specify Marley Plumbing and Drainage products.

Whilst every effort is made to ensure details are accurate and up to date, our continual product development and improvement programme, may cause dimensional details to change.

Technical Hotline: 01622 852695

Fax: 01622 858041

Email: technical@marleyext.com

Availability

Marley Plumbing and Drainage Products are available from a national network of distributors and stockists. For details of your local stockist contact the Marley Plumbing and Drainage Head Office or Scottish Office as listed below.

Head Office

Lenham, Maidstone, Kent ME17 2DE
Telephone: 01622 858888 Fax: 01622 858725
marley.co.uk

Further information

For Technical advice please call **01622 852695**
For general enquiries and details of your nearest stockist please call the customer services department on **01622 852585**
email: marketing@marleyext.com

Scotland

Birkenshaw Industrial Estate, Uddingston, Glasgow G71 5PA
Telephone: 01698 815231 Fax: 01698 810307

Export Division

Lenham, Maidstone, Kent ME17 2DE England
Telephone: +44 (0)1622 858888 Fax: +44 (0)1622 850778

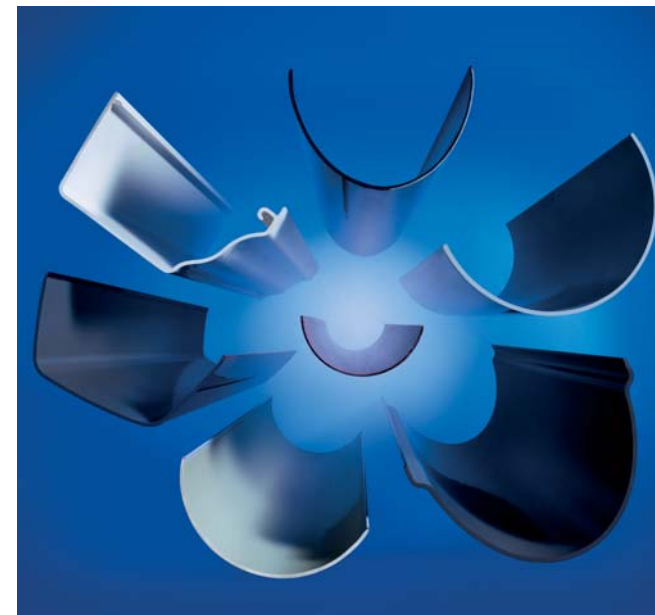

Environment

The environment is one of the most important issues in today's society. As a manufacturer, Marley Plumbing & Drainage places great emphasis on ensuring that all manufacturing processes and practices are environmentally responsible. This extends to packaging as well as raw material handling and process controls. Marley also play an active role at industry level via the British Plastics Federation, where broader industry wide environmental issues are addressed.

British Plastics Federation: Tel: 020 7457 5000

British & European Standards

British standards

BS EN ISO 9001: 1997 - Quality systems. Model for Quality Assurance in Production, Installation and Servicing.

BS 4576: Part 1: 1989 - Specification for PVCu half round gutters and circular pipe.  Kite Mark licence No. 7079.

BS EN 607: 1996 - Eaves gutters & fittings - PVCu. Definitions, requirements and testing.

BS EN 1462: 1997 - Gutter brackets. Classification, requirements & testing.

BS 4514: 1983 - Specification for PVCu, soil and ventilating pipes, fittings and accessories.  Kite Mark licence No. 5265.

BS EN 1329-1: 2000 - Plastics piping systems for soil and waste discharge systems - PVCu.  Kite Mark licence No. 56356.

BS EN 12200-1: 2000 - Plastics rainwater piping systems for above ground external use - PVCu.

BS 4255: Part 1: 1986 - Specification for non-cellular gaskets for buildings.

BS EN 12056-3: 2000 - Gravity drainage inside buildings: Roof drainage, layout and calculation.

BS EN 681-1 - Elastomeric seals- vulcanised rubber. Material requirements for pipe joint seals used in water & drainage applications.

EN 681-2- Elastomeric seals - Thermoplastics Elastomers. Material requirements for pipe joint seals used in water and drainage applications.



BS 4576:1989
BS EN 1329-1:2000



FM30637

• Products indicated by this symbol comprise of components not covered by Marley Plumbing and Drainage BS EN ISO 9001 Scope of Registration. However these products have been fully inspected and tested in accordance with our own Quality Management System requirements.

Also available from Marley Plumbing & Drainage:

Alutec aluminium rainwater systems•

Alutec roof, floor & shower outlets•

Soil & Waste systems

Underground drainage systems including Quantum highway & sewer systems

Equator hot & cold water systems

Waterloc Stormwater management systems

Flowloc control device

	Colour Availability					Size	British/ European Standard
	Black	Chestnut Brown	Grey	White	Sand		
<p>Deepflow Deepflow was the first semi-elliptical profile PVCu gutter system in the UK. Still the market leader, the Deepflow profile produces self cleansing flow resulting in a very high capacity. Deepflow can be jointed using a notched or notchless joint (see page 35 for full details). Downpipe: 68mm circular.</p> <p>see page 14</p>	<input type="checkbox"/>	<input type="checkbox"/>	<input type="checkbox"/>	<input type="checkbox"/>	<input checked="" type="checkbox"/>	110 x 75mm	BS EN 607
<p>Clip-master Clip-master is a practical, easy to install PVCu nominal half round gutter system. Designed for fast, easy installation. Clip-master is not only very cost effective but is compatible with most other manufacturers' half round systems. Clip-master can be jointed using a notched or notchless joint (see page 35 for full details).</p> <p>see pages 15 & 16</p>	<input type="checkbox"/>	<input type="checkbox"/>	<input type="checkbox"/>	<input type="checkbox"/>	<input checked="" type="checkbox"/>	112 x 49mm	BS EN 607
<p>68 mm Circular Downpipe With the distinctive "Marley" socket, 68mm downpipe is suitable for use with Deepflow, Clip-master, Flowline & Classic gutter systems.</p> <p>see pages 17 & 18</p>	<input type="checkbox"/>	<input type="checkbox"/>	<input type="checkbox"/>	<input type="checkbox"/>	<input checked="" type="checkbox"/>	68mm	BS EN 12200
<p>Flowline Flowline is an attractive rectilinear profile PVCu gutter system. Capable of carrying capacities in excess of standard half round gutters. Flowline is the aesthetic choice for larger roof areas. Flowline can be jointed using a notched or notchless joint (see page 35 for full details). Downpipe: 68mm circular/65mm square.</p> <p>see page 19</p>	<input type="checkbox"/>	<input type="checkbox"/>	<input type="checkbox"/>	<input type="checkbox"/>	<input checked="" type="checkbox"/>	112 x 60mm	BS EN 607
<p>Classic Classic is a bold, highly decorative, Ogee style PVCu gutter system, featuring both internal and external fascia brackets. All Classic fittings are supplied complete with clips and seals. Outlets and unions incorporate screw fixing points to anchor fittings for the control of thermal movement. Downpipe: 68mm circular/65mm square.</p> <p>see pages 20 & 21</p>	<input type="checkbox"/>	<input type="checkbox"/>	<input type="checkbox"/>	<input type="checkbox"/>	<input checked="" type="checkbox"/>	116 x 75mm	BS EN 607
<p>65 mm Square Downpipe Designed primarily for use with Flowline and Classic gutter systems, but can be used in conjunction with hopper heads using an adaptor.</p> <p>see pages 22 & 23</p>	<input type="checkbox"/>	<input type="checkbox"/>	<input type="checkbox"/>	<input type="checkbox"/>	<input checked="" type="checkbox"/>	65mm	BS EN 12200
<p>Miniline Marley Miniline is specially designed to efficiently drain smaller roof areas such as porches, greenhouses and sheds.</p> <p>see page 24</p>	<input type="checkbox"/>	<input type="checkbox"/>	<input type="checkbox"/>	<input type="checkbox"/>	<input checked="" type="checkbox"/>	75 x 33mm	BS EN 607

	Colour Availability					Size	British/ European Standard
	Black	Chestnut Brown	Grey	White	Sand		
<p>Miniline Circular Downpipe For use with the miniline gutter system. The downpipe features a formed socket on each length.</p> <p>see page 25</p>	<input type="checkbox"/>	<input type="checkbox"/>	<input type="checkbox"/>	<input type="checkbox"/>	<input checked="" type="checkbox"/>	53mm	
<p>Deepflow150 Deepflow150 is a larger version of the Deepflow profile and is ideal for small to medium commercial projects, flats and industrial applications. Deepflow150 can be jointed using a notched or notchless joint.</p> <p>see page 26</p>	<input type="checkbox"/>	<input type="checkbox"/>	<input type="checkbox"/>	<input type="checkbox"/>	<input checked="" type="checkbox"/>	150 x 90mm	BS EN 607
<p>82mm Circular Downpipe With the distinctive "Marley" socket, 82mm downpipe is suitable for use with the Deepflow150 gutter systems.</p> <p>see page 27</p>	<input type="checkbox"/>	<input type="checkbox"/>	<input type="checkbox"/>	<input type="checkbox"/>	<input checked="" type="checkbox"/>	82mm	BS EN 12200
<p>Industrial 150mm true half round Industrial PVCu gutter system is designed to meet the requirements of large commercial and industrial installations. Capable of carrying up to 5.80 litres a second. Industrial is jointed using the notched technique. Downpipe: 110mm circular.</p> <p>see page 28</p>	<input type="checkbox"/>	<input type="checkbox"/>	<input type="checkbox"/>	<input type="checkbox"/>	<input checked="" type="checkbox"/>	150 x 75mm	BS 4576 BS EN 607
<p>110, 160mm Circular Downpipe For use with the Industrial gutter system, Marley flat roof outlets and hopper heads.</p> <p>see pages 29 & 30</p>	<input type="checkbox"/>	<input type="checkbox"/>	<input type="checkbox"/>	<input type="checkbox"/>	<input checked="" type="checkbox"/>	110mm, 160mm	BS 4514 BS EN 1329
<p>Flat Roof Outlets Marley PVCu rainwater systems include a wide range of outlets and fittings for all internally drained flat roofs. Marley outlets are suitable for most types of flat roof construction. The balcony outlet has a specifically designed low profile grating.</p> <p>see page 31</p>	<input type="checkbox"/>	<input type="checkbox"/>	<input type="checkbox"/>	<input type="checkbox"/>	<input checked="" type="checkbox"/>	68mm 110mm	
<p>Hopper Heads A wide range of hoppers in different styles are available to suit three sizes of downpipe.</p> <p>see page 32</p>	<input type="checkbox"/>	<input type="checkbox"/>	<input type="checkbox"/>	<input type="checkbox"/>	<input checked="" type="checkbox"/>	68mm 82mm 110mm 160mm	

Roof drainage design

Design basis

To assess the suitability of a gutter system to drain the roof to a building the following factors need to be taken into consideration:

1. The effective roof area to be drained.
2. Rainfall intensity.
3. The flow characteristics of the gutter system.
4. The number and position of downpipes.

Effective roof area

The effective roof area can be determined by calculation in accordance with the following:

1. BS EN 12056-3:2000, Gravity drainage inside buildings.
2. The Building Regulations 2002 Approved Document H, Part H3.

The formula and example shown opposite reflects the method used in the above standard to calculate effective roof area.

Multiplication factors

An alternative approach to that described above is the use of multiplication factors to establish effective roof area. From plan area the appropriate factor for the roof slope can be applied to determine the effective area. This method is similar to that shown in Approved Document H of the Building Regulations. The table below provides a wider range of factors to enable accurate assessment of effective roof area to be determined.

Roof pitch	Factor	Roof pitch	Factor
10°	1.088	30°	1.288
12.5°	1.111	32.5°	1.319
15°	1.134	35°	1.350
17.5°	1.158	37.5°	1.384
20°	1.182	40°	1.419
22.5°	1.207	42.5°	1.459
25°	1.233	45°	1.500
27°	1.260	47.5°	1.547

For roofs of 50° and above a factor of 1.600 may be used.

Vertical surfaces

Where pitched roofs abut vertical walls the catchment area is likely to be increased as a result of wind driven rain. To allow for this half the vertical surface area of the wall should be added to the effective area of the sloping roof.

Flat roofs

For roofs with a pitch of less than 10° the effective area is taken as the plan area.

Rainfall intensity

The Building Regulations 2002 Approved Document H recommends a flat rate rainfall intensity of 0.021 litres/second per square metre of roof area be used for design calculations. This intensity is virtually the same as 75mm/hour that has been used for the design of eaves gutter systems since the publication of BS 6367 in 1983 which has now been withdrawn.

Where a flat rate rainfall intensity is not adopted for the purpose of design, reference should be made to BS EN 12056-3: 2000 which provides detailed information on rainfall throughout the UK by geographical location and frequency of occurrence. The flow rates shown on page 11 for Marley PVCu gutter systems have been determined from tests carried out in accordance with the test procedure in BS EN 12056-3: 2000.

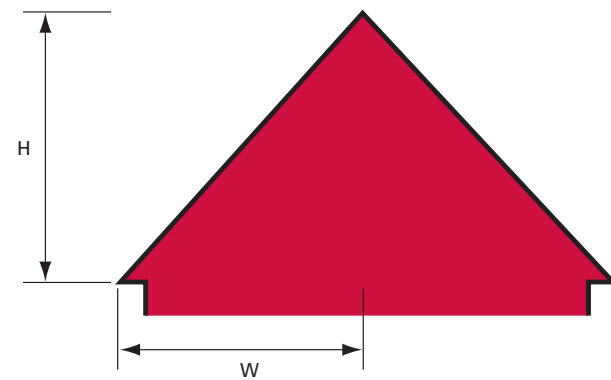

$$\left(\frac{H}{2}\right) + W \times L = m^2$$

For example a roof 4m high x 4m wide x 10m long

$$2 + 4 \times 10 = 60m^2$$

Multiplication factor method

Using the same roof dimensions as the example above with a 45° roof pitch.

$$4m \text{ wide} \times 10m \text{ long} \times 1.5 = 60m^2$$

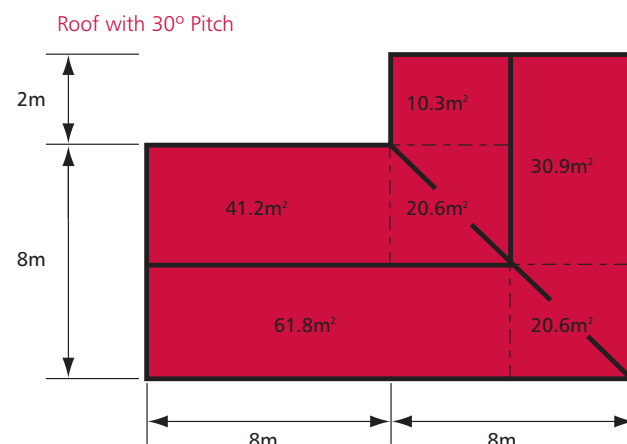
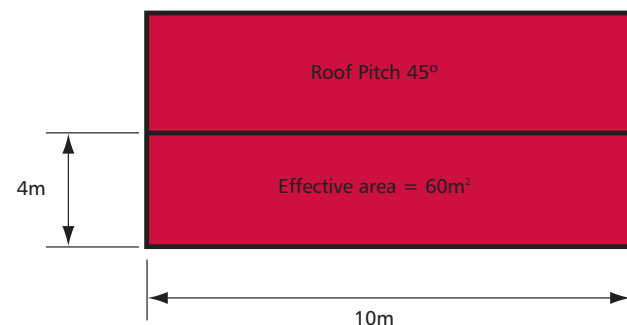

Roof drainage design

Gutter selection

Although aesthetic appearance is an important aspect in the selection of a particular gutter system, the following factors also need to be taken into consideration as they could influence the final choice of system.

1. The size of gutter and its flow capacity.
2. Whether the gutter is fitted level or to a fall.
3. If end or centre outlet position for downpipes are adopted.
4. The length of gutter to an outlet/downpipe.

Flow capacity

The maximum flow capacity of different Marley gutter systems can be compared from the tables shown opposite. It can be observed that the capacity of each system varies depending on profile, size and whether the gutter is fitted level or to a fall. For design purposes eaves gutters are normally sized to ensure the calculated run-off does not exceed 90% of the gutter capacity. It is also recommended that gutters are fixed level as this enables the gutter to be fitted as high as possible to ensure the correct relationship is maintained at the roof edge.

In order to combine appearance with optimum performance, careful consideration needs to be given to the position of outlets bearing in mind the flow characteristics of each system. It can be seen that a centre outlet is more efficient than an end outlet as the area that can be drained is almost double. As a result it may be possible to reduce or eliminate the number of rainwater pipes required and thereby introduce economies through good design.

Rainwater pipe sizes

With the exception of the Industrial, Deepflow150 and Miniline gutter systems which have 110mm, 82mm and 53mm diameter downpipes respectively, all other Marley PVCu gutter systems incorporate outlets suitable for 68mm circular or 65mm square rainwater pipes. This size of downpipe has been selected as it has the necessary capacity to accommodate the maximum flow from any of the gutter systems.

Effect of valleys

Where valleys occur it is good practice to position an outlet adjacent to the internal angle to deal with the concentrated discharge that is likely at such points during peak flow conditions. Depending on the size of roof it may also be beneficial to fit a corner hopper where the flow is considerable.

Long roofs

The spread of water as it leaves the roof edge varies considerably depending on the roof surface and pitch. On long roofs it may be necessary to select a wider gutter than capacity calculations would normally dictate. This is particularly important with sheet metal or similar profiled roofs where there is a tendency for the discharge to follow the roof angle and overshoot the gutter.

Gutter length

On long runs frictional resistance can reduce gutter capacity and efficiency. To allow for this, reduction factors can be applied or gutters sized to allow freeboard in accordance with BS EN 12056-3: 2000 recommendations.

Flat roof outlets and hopper heads

The flow characteristics of different size flat roof outlets and hopper heads are shown on page 40.

Outlet at one end

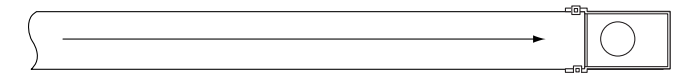

Gutter system	level		fall 1:600	
	m²	l/s	m²	l/s
Miniline	15	0.33	19	0.40
Clip-master	43	0.90	48	1.00
Flowline	70	1.46	84	1.75
Deepflow	90	1.90	110	2.31
Classic	103	2.16	---	---
Deepflow150	133	2.80	---	---
Industrial	127	2.67	152	3.20

Outlet at one end with an angle within 2m of outlet



Gutter system	level		fall 1:600	
	m²	l/s	m²	l/s
Miniline	13	0.27	17	0.35
Clip-master	39	0.81	43	0.90
Flowline	63	1.31	76	1.58
Deepflow	81	1.70	99	2.07
Classic	93	1.94	---	---
Industrial	116	2.44	138	2.90

For gutters with angles further than 2m from the outlet increase the above figures by 5%.

Outlet in the centre



Gutter system	level		fall 1:600	
	m²	l/s	m²	l/s
Miniline	25	0.54	30	0.64
Clip-master	84	1.75	92	1.92
Flowline	135	2.84	170	3.40
Deepflow	185	3.90	226	4.75
Classic	216	4.55	---	---
Deepflow150	286	6.00	---	---
Industrial	270	5.68	326	6.84

The Marley Rainwater Product Range

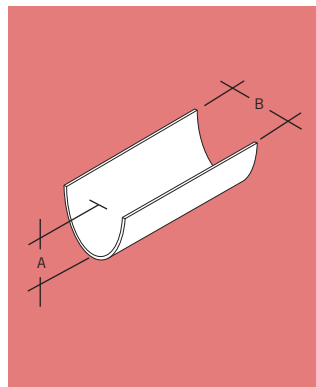

Gutter

Code	Nominal Length m	CSA mm ²	A		B	
			A	B	A	B
RGD3	3	6043	75	110		
RGD4	4	6043	75	110		

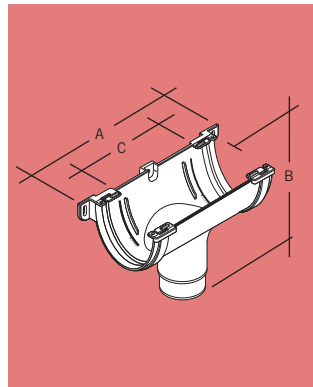

Running outlet

Code	A	B	C
ROD10	275	164	153

68 mm circular spigot

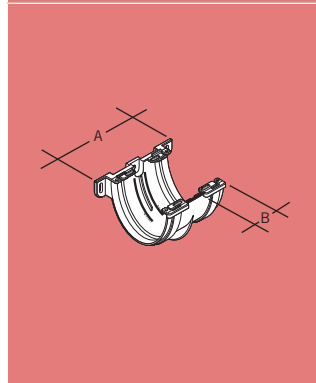

Union bracket

Code	A	B
RUD10	155	40

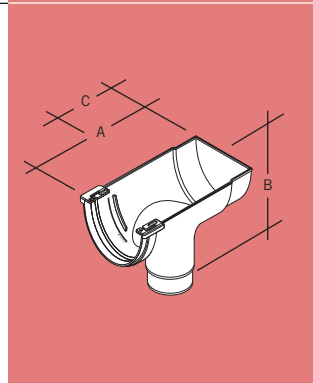

Stopend outlet

Code	A	B	C
ROD20	227	164	107

68 mm circular spigot

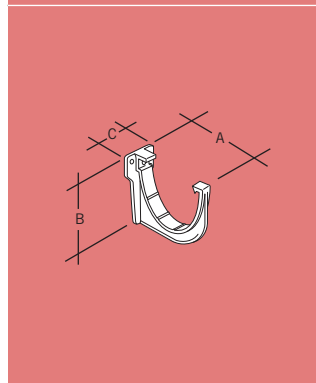

Fascia bracket

Code	A	B	C
RKD1	131	100	50

Three screw holes

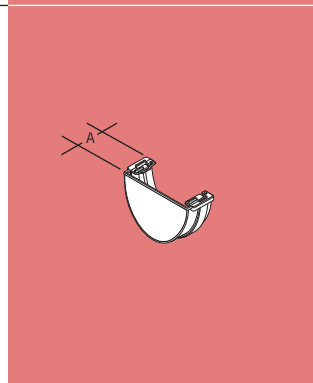

External stopend

Code	A
RED10	44

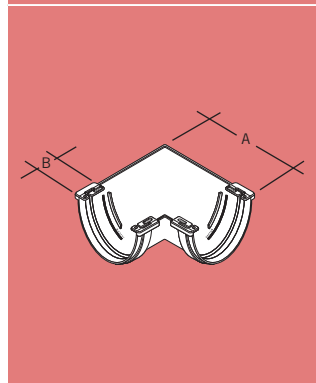

Angle

Code	Angle	A	B
RAD10	90°	176	40

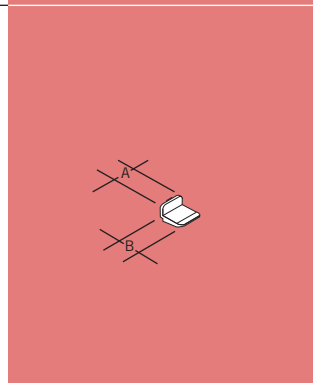

Notch adaptor

Code	A	B
RGNA1	16	18

To adapt fitting for notch jointing

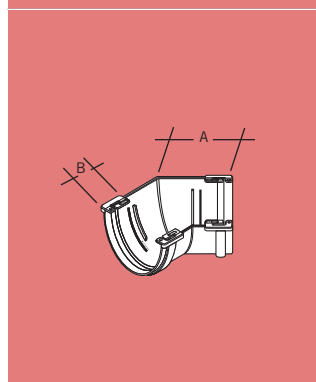

Angle

Code	Angle	A	B
RAD20	45°	108	40

Special gutter angles are available to order (RFB21)

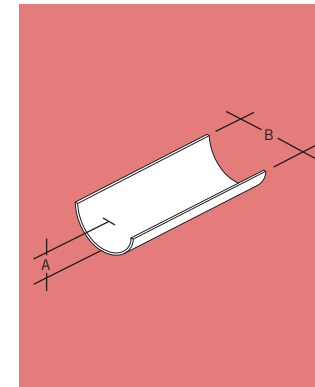

Gutter

Code	Nominal Length m	CSA mm ²	A		B	
			A	B	A	B
RGC3	3	3997	49	112		
RGC4	4	3997	49	112		

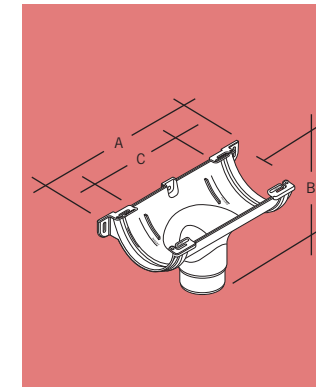

Running outlet

Code	A	B	C
ROC1	275	138	155

68 mm circular spigot

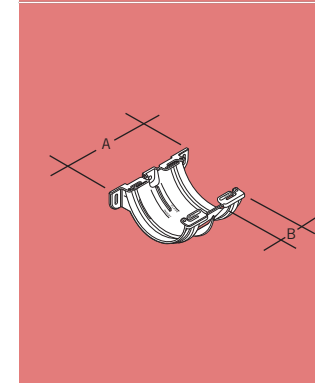

Union bracket

Code	A	B
RUC1	155	40

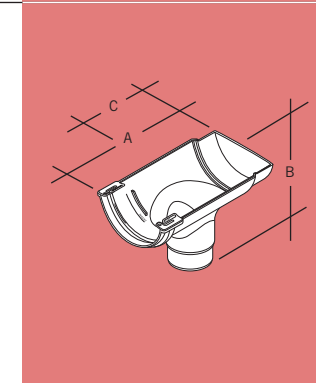

Stopend outlet

Code	A	B	C
ROC2	228	138	105

68 mm circular spigot

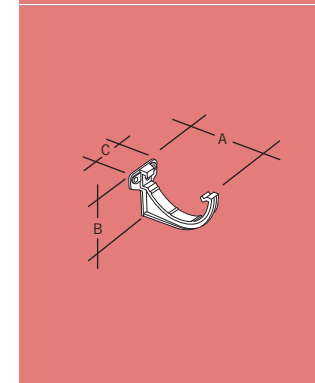

Fascia bracket

Code	A	B	C
RKC1	132	72	48

Three screw holes

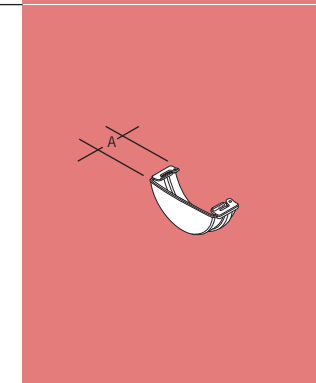

External stopend

Code	A
REC1	40

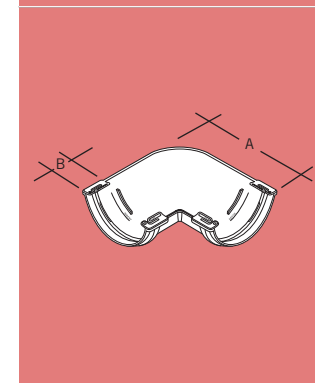

Angle

Code	Angle	A	B
RAC1	90°	170	40

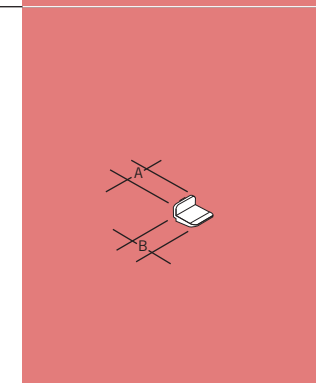

Notch adaptor

Code	A	B
RGNA1	16	18

To adapt fitting for notch jointing

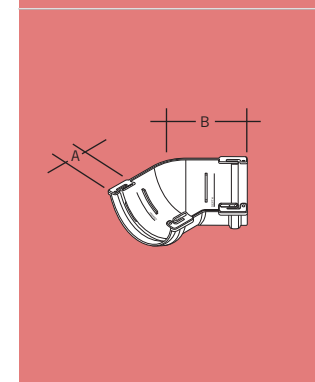

Angle

Code	Angle	A	B
RAC2	45°	110	40

Special gutter angles are available to order (RFB104)

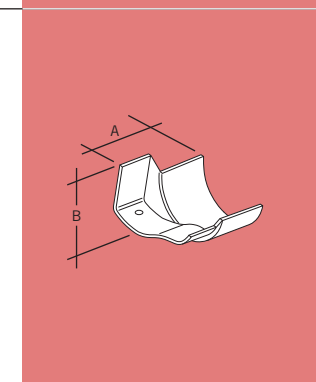

Clip-master/Ogee adaptor

Code	A	B
RGAA4 Right Hand	94	66
RGAA5 Left Hand	94	66

Cast aluminium, Clip-master spigot to standard Ogee socket
Left hand illustrated

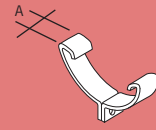

Half round gutter adaptor

Code	A
RGA1R	29

Black only. Including nut, bolt and seal
Suitable for adapting 100 mm to 112 mm half round cast iron, aluminium or PVCu gutters

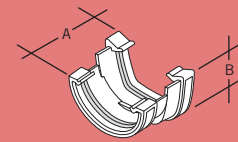

Clip-master to Flowline adaptor

Code	A	B
RGA2R	87	72

Black, White & Chestnut Brown

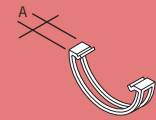

Spare clip

Code	A
RCC1	24

For use with old Clip-master system only

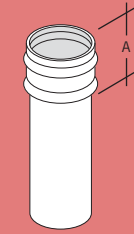

Pipe

Code	Nominal Length m	A
RPH2525	2.5	52
RPH253	3	52
RPH2555	5.5	52

RPH2525 is not available in white

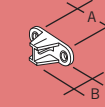

Backplate

Code	A	B
RCB300	48	30

For use with RC251/RC252 pipe clips

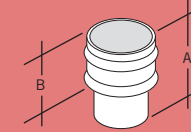

Loose pipe socket

Code	A	B
RL25	100	50

For loose jointing to cut pipe
Spigot fits into cut pipe

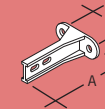

Extension backplate

Code	A	B
RT200	104	45

8 mm screw fixing holes

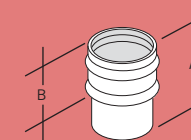

Pipe socket

Code	A	B
RLR25	92	50

Ring seal solvent socket

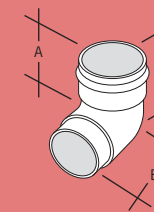

Bend

Code	Angle	A	B	C
RB251	87½°	48	75	81
RB252	67½°	38	60	66
RB253	45°	48	53	63

Socket/spigot
RB251 illustrated

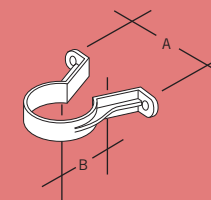

One piece pipe clip

Code	A	B
RC253	94	72

8 mm screw fixing holes

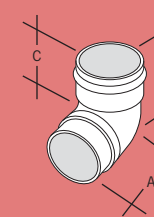

Offset bend

Code	Angle	A	B	C
RNE255	67½°	66	66	37

Socket/spigot
Spigot has push fit connection to pipe

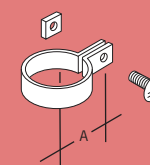

Clip

Code	A
Socket Clip	
RC251	64
Pipe Clip	
RC252	64

For use with RCB300 backplate
Including nut and bolt 6 x 20 mm



Offset bend

Code	Angle	A	B
RNA250	67½°	41	15

Socket/socket for solvent weld jointing
For deep fascias

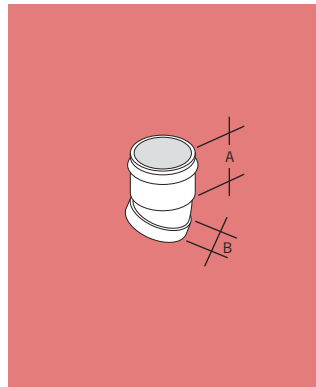

Offset bend

Code	Angle	A	B
RNE252	20°	51	15

Socket/socket
For 25 mm offset construction

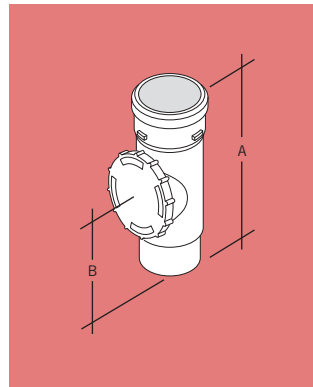

Access pipe

Code	A	B
RF25	185	96

Socket/spigot

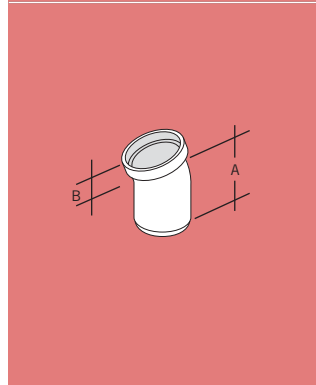

Offset bend

Code	Angle	A	B
RNE253	20°	56	15

Socket/spigot
For 25 mm offset construction

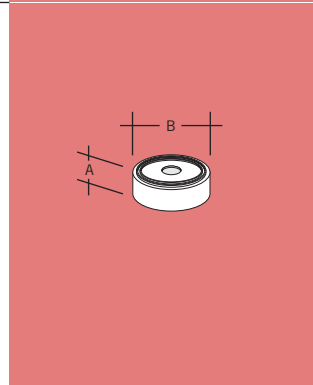

Adaptor

Size mm	Code	A	B
110	RA42	31	104

Rainwater to 110mm drain adaptor

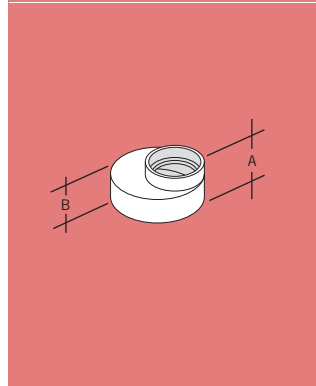

Reducers

Code	Size mm	A	B
RRM425	110 x 68	40	25
SRM325	82 x 68	35	20

Socket/socket

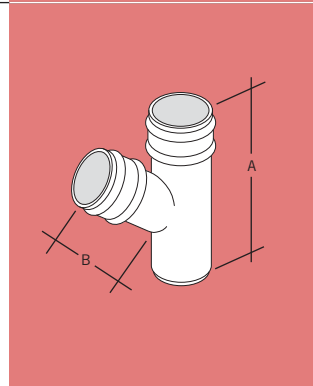

Branch

Code	Angle	A	B
RY252	67½°	196	90

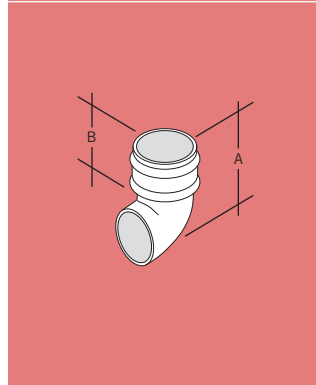

Shoe

Code	A	B
RS25	137	48

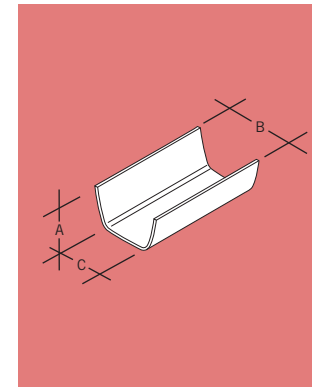

Gutter

Code	Nominal Length m	CSA mm²	A	B	C
RGF4	4	5412	60	112	80

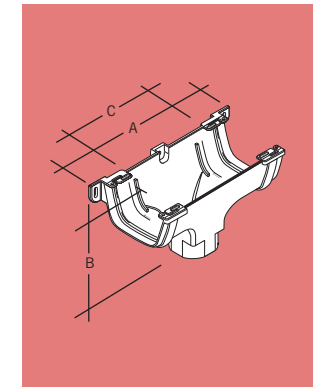

Running outlet

Code	A	B	C
ROF1	275	134	155

Suitable for both 68 mm circular or 65 mm square downpipe

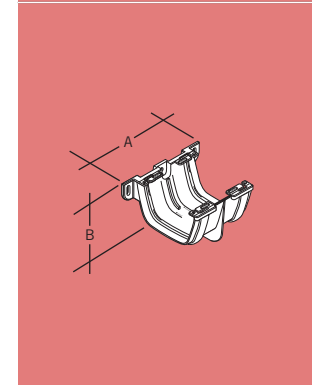

Union bracket

Code	A	B
RUF1	155	84

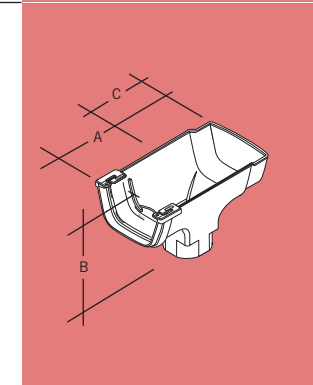

Stopend outlet

Code	A	B	C
ROF11	225	134	110

Suitable for both 68 mm circular or 65 mm square downpipe

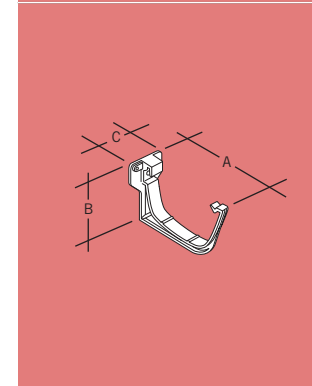

Fascia bracket

Code	A	B	C
RKF2	132	85	48

Three screw holes

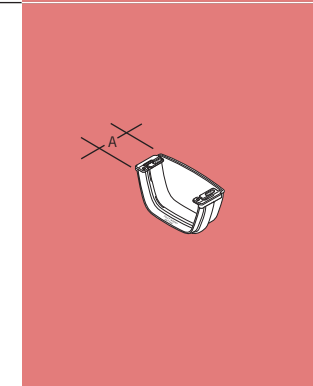

External stopend

Code	A
REF2	53

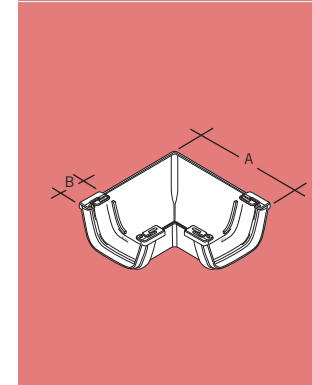

Angle

Code	Angle	A	B
RAF1	90°	188	40

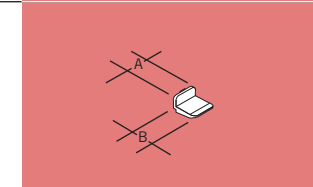

Notch adaptor

Code	A	B
RGNA1	16	18

To adapt fitting for notch jointing

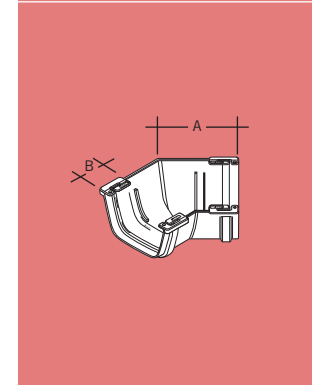

Angle

Code	Angle	A	B
RAF2	45°	110	40

Special gutter angles are available to order (RFB102)

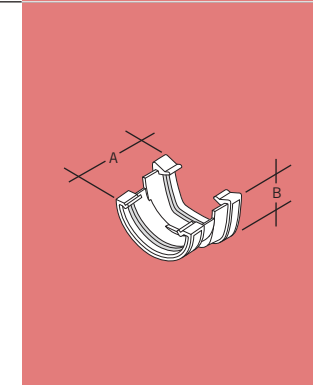

Clip-master to Flowline adaptor

Code	A	B
RG2R	87	72

Black, White & Chestnut Brown

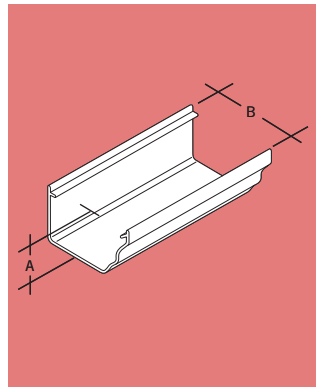

Gutter

Code	Nominal Length m	CSA mm ²	A	B
RCG54	4	7377	75	116

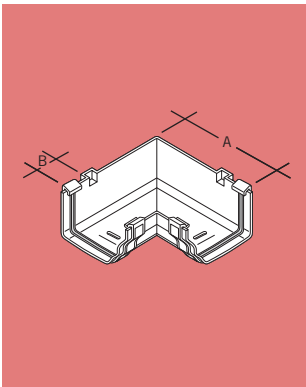

Internal angle

Code	Angle	A	B
RCA52	90°	189	50

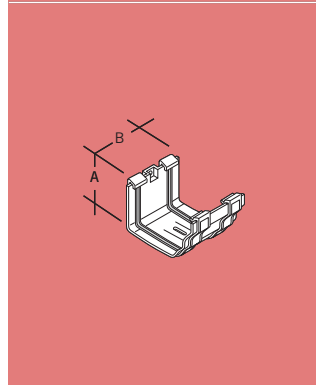

Union bracket

Code	A	B
RCU51	88	100

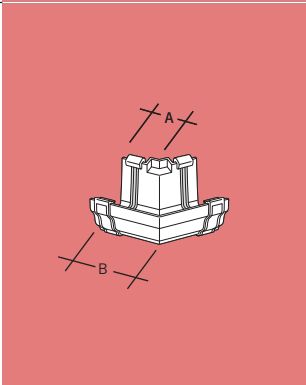

External angle

Code	Angle	A	B
RCA511	45°	52	109
RCA510	30°	59	95

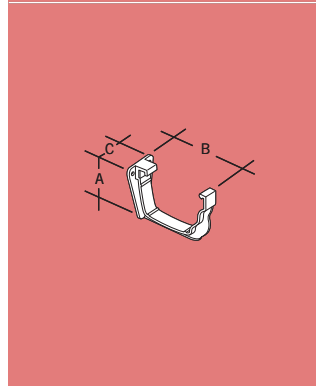

Fascia bracket

Code	A	B	C
RCK51	98	136	54

External
Three screw fixings

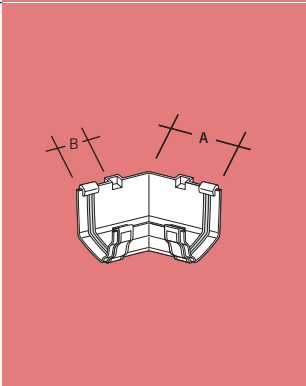

Internal angle

Code	Angle	A	B
RCA522	45°	109	50

Special gutter angles to order (RFB401/501)

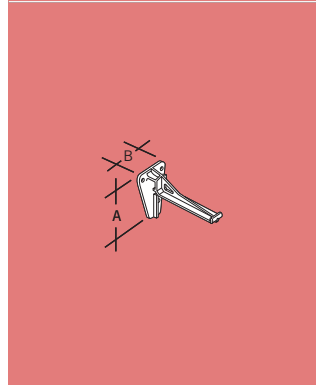

Fascia bracket

Code	A	B
RCK52	84	54

Internal
Three screw fixings and centre bolt hole

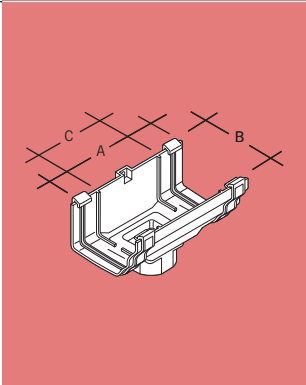

Running outlet

Code	A	B	C
RCO50	222	135	125

Suitable for both 68 mm circular or 65 mm square downpipe

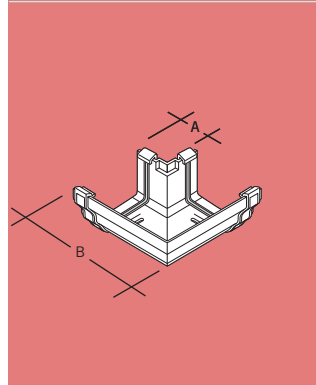

External angle

Code	Angle	A	B
RCA51	90°	52	189

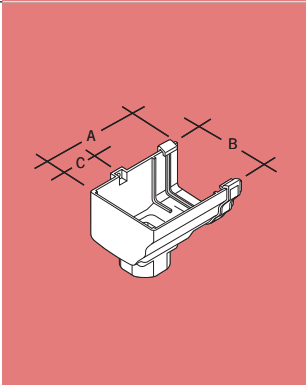

Stopend outlet

Code	A	B	C
RCO51	177	135	66

Left hand
Suitable for both 68 mm circular or 65 mm square downpipe

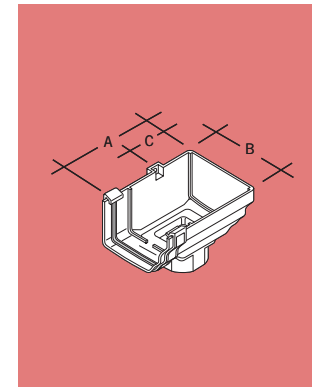

Stopend outlet

Code	A	B	C
RCO52	177	135	66

Right hand
Suitable for both 68 mm circular or 65 mm square downpipe

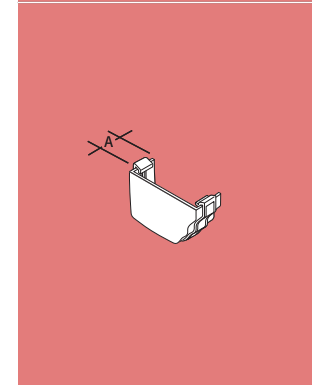

External stopend

Code	A
RCE51	41

Left hand

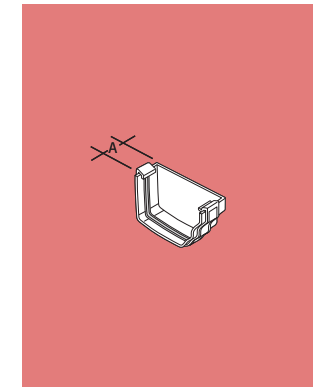

External stopend

Code	A
RCE52	41

Right hand

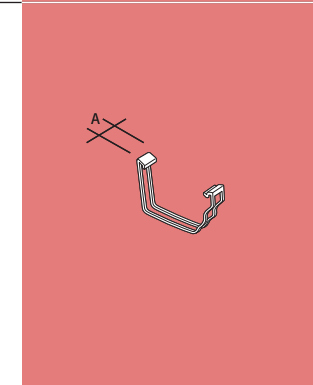

Spare clip

Code	A
RCC51	24

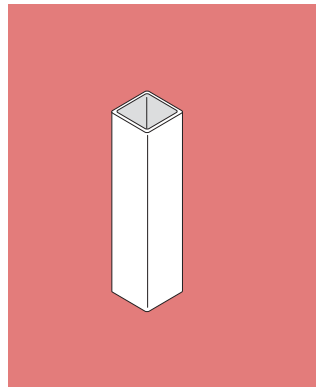

Pipe

Code	Nominal Length m
RPE3	3
RPE2555	5.5

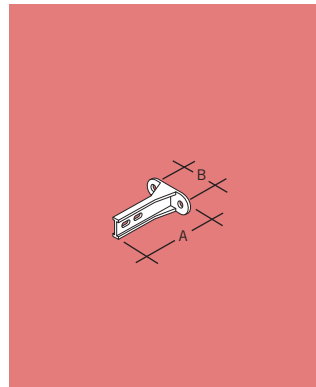

Extension backplate

Code	A	B
RT200	104	45

8 mm screw fixing holes

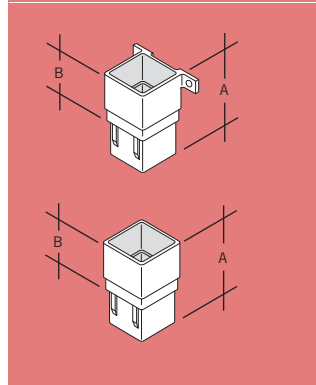

Pipe socket

Code	A	B
RLE1 (with fixing lugs)	82	42
RLE11 (plain)	82	42

Spigot has push fit connection to pipe

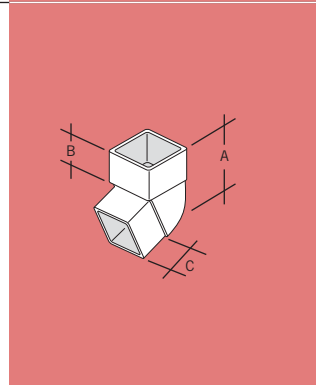

Offset bend

Code	Angle	A	B	C
RBE1	67½°	75	42	40

Socket/spigot
Spigot has push fit connection to pipe

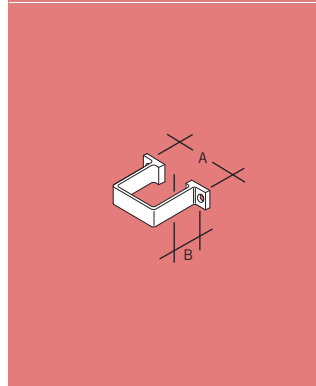

One piece pipe clip

Code	A	B
RCE1	88	40

8 mm screw fixing holes

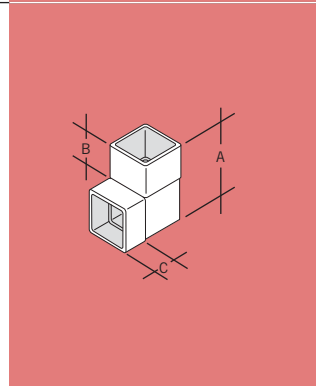

Offset bend

Code	Angle	A	B	C
RBE3	87½°	104	40	28

Socket/socket

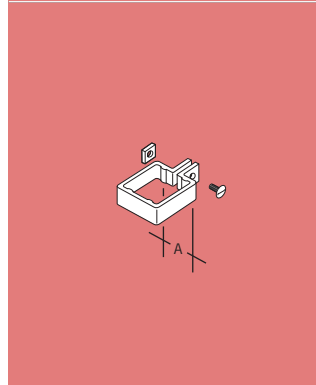

Pipe clip

Code	A
RCE2	56

For use with RCB300 backplate
Including nut and bolt

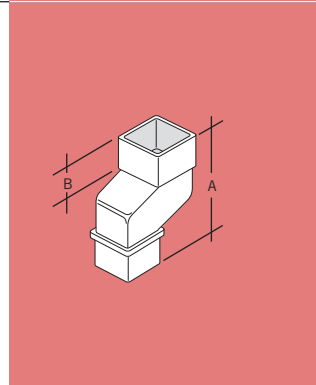

Offset

Code	A	B
RNE1	142	42

Socket/spigot
50 mm offset projection

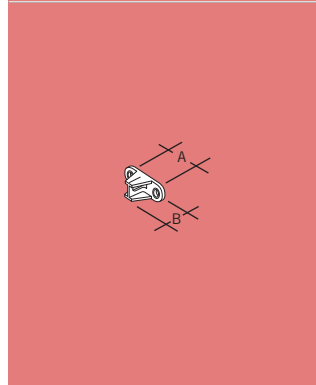

Backplate

Code	A	B
RCB300	48	30

For use with RCE2 pipe clip
8 mm screw fixing holes

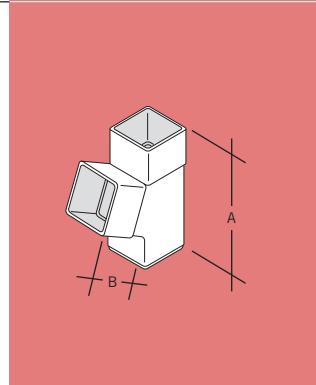

Branch

Code	Angle	A	B
RYE1	67½°	158	75

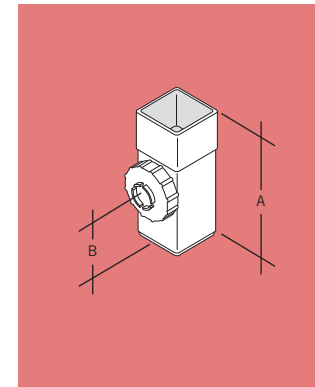

Access pipe

Code	A	B
RFB91	222	95

Socket/spigot

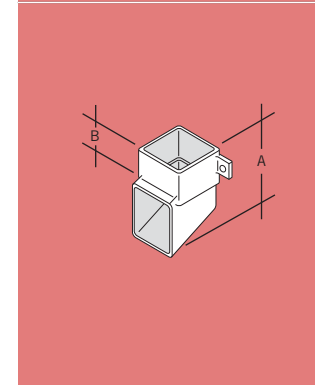

Shoe

Code	A	B
RSE1 (with fixing lugs)	115	40

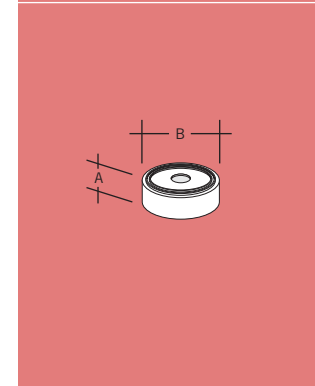

Adaptor

Size mm	Code	A	B
110	RA42	31	104

Rainwater to 110mm drain adaptor

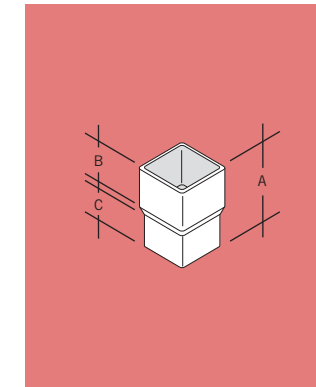

Outlet adaptor

Code	A	B	C
RLE3	96	51	41

Socket/spigot
For use with RLE11 to adapt RH25 to suit 65mm square downpipe

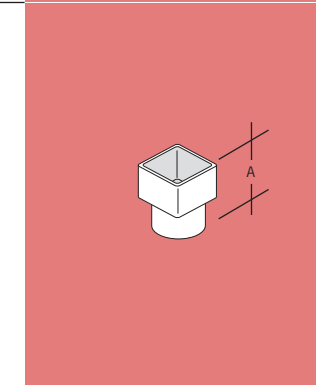

Drain adaptor

Code	A
RLE2	77

65 mm square socket to 68 circular spigot

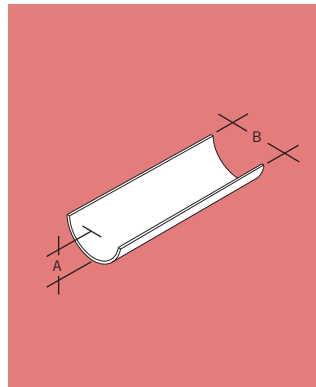

Gutter

Code	Nominal Length m	CSA mm ²	A	B
RMG2	2	1480	33	75

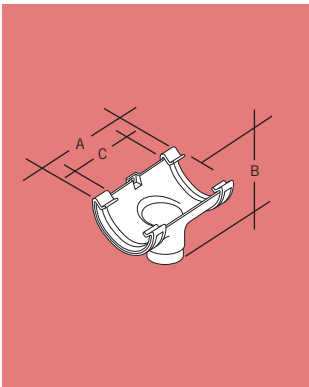

Running outlet

Code	A	B	C
RMO1	139	87	91

51 mm circular spigot

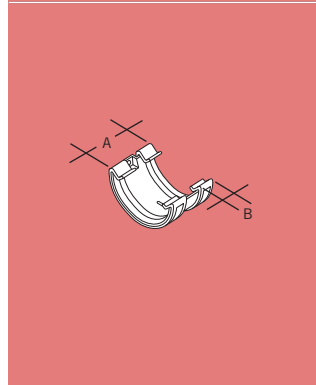

Union

Code	A	B
RMU1	65	20

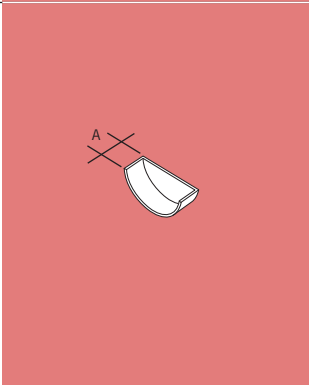

Internal stopend

Code	A
RME1	25

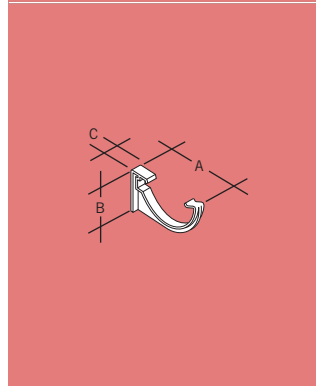

Fascia bracket

Code	A	B	C
RMK1	88	48	14

One screw hole fixing

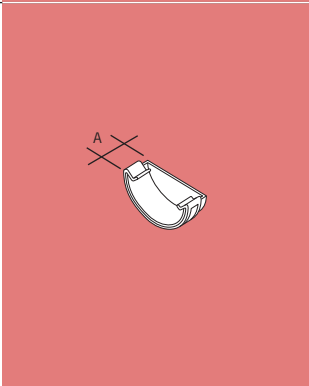

External stopend

Code	A
RME2	32

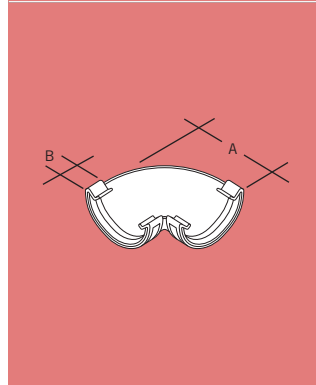

Angle

Code	Angle	A	B
RMA1	90°	90	20

Special gutter angles are available to order (RFB105)

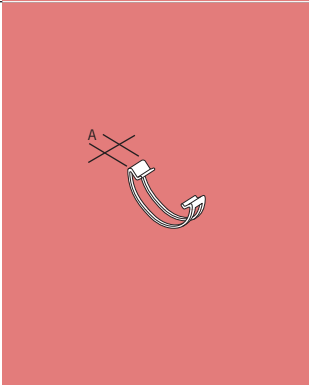

Spare clip

Code	A
RMC1	19

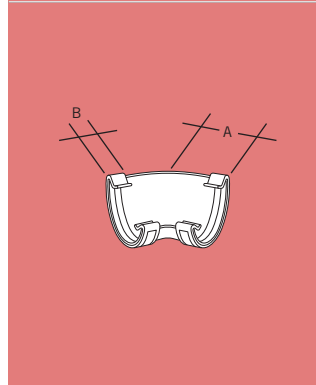

Angle

Code	Angle	A	B
RMA2	45°	67	20

Special gutter angles are available to order (RFB105)

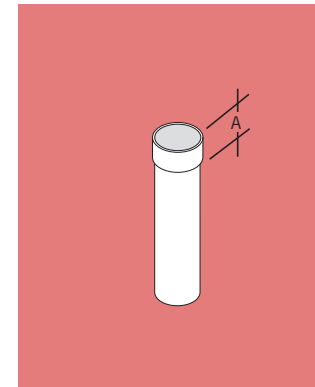

Pipe

Code	Nominal Length m	A
RPS2	2	48

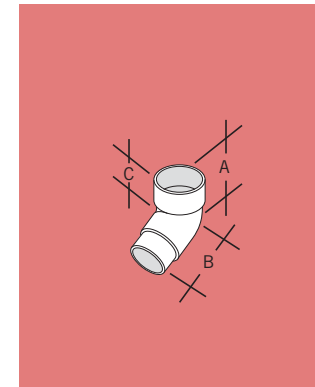

Offset bend

Code	Angle	A	B	C
RNS1	67½°	72	70	32

Socket/spigot
Spigot has push fit connection to pipe

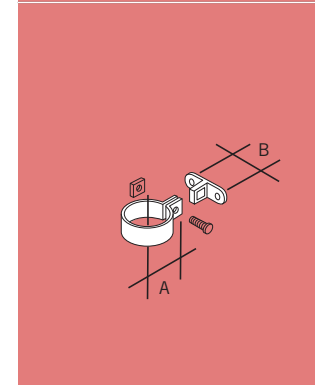

Pipe clip & back plate

Code	A	B
RCS1	45	35

Including nut and bolt
5 mm screw fixing holes

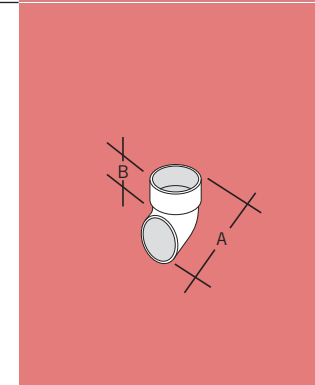

Shoe

Code	A	B
RSN2	93	32

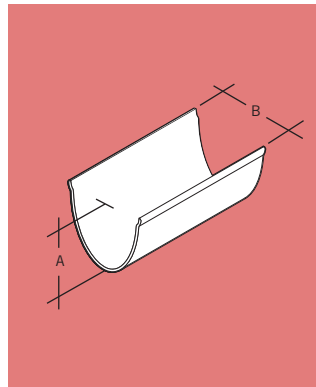

Gutter

Code	Nominal Length m	CSA mm ²	A	B
RGJ4	4	10,060	98	155

Co-extruded

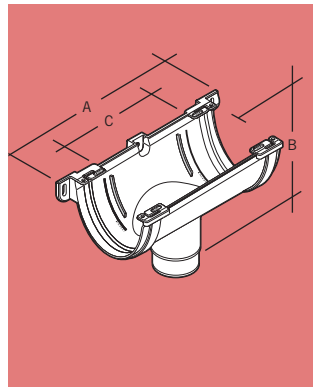

Running outlet

Code	A	B	C
ROJ1	281	192	160

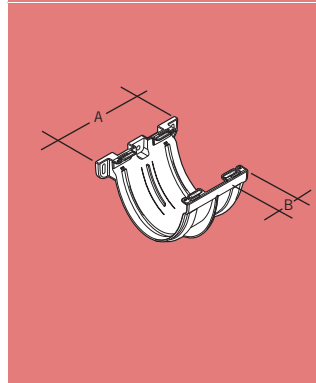

Union

Code	A	B
RUJ1	166	40

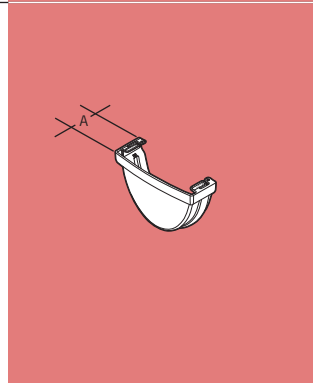

External stopend

Code	A
REJ1	55

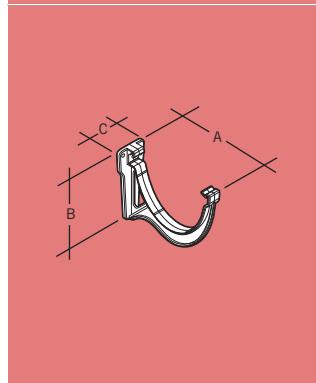

Fascia bracket

Code	A	B	C
RKJ1	174	125	49

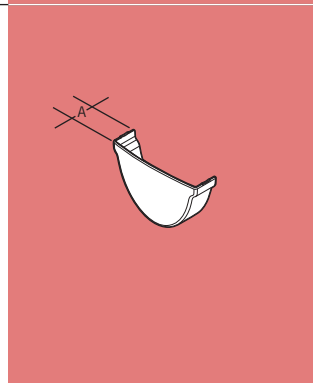

Internal stopend

Code	A
REJ2	44

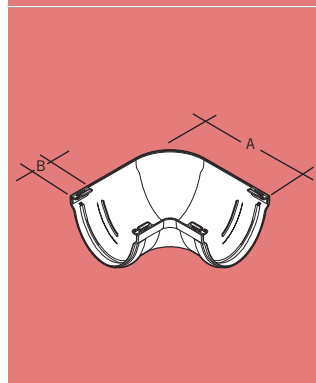

Angle

Code	Angle	A	B
RAJ1	90°	241	40

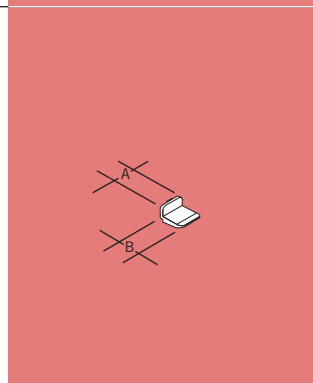

Notch adaptor

Code	A	B
RGNA1	16	18

To adapt fitting for notch jointing.
Available in black only.

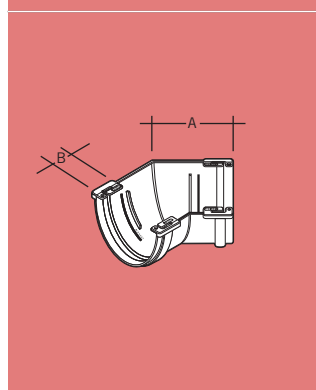

Angle

Code	Angle	A	B
RAJ2*	45°	140	40

* Fabricated

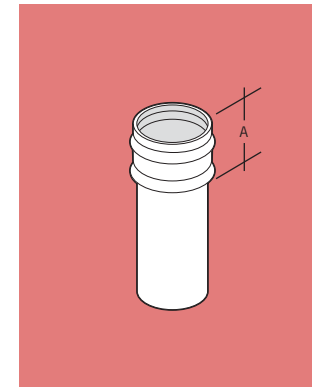

Downpipe

Size mm	Code	A	Length m
82.4	RPH33	61	3m

Integral socket co-extruded

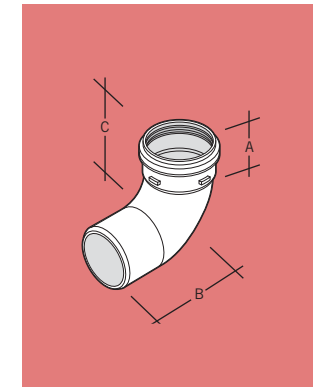

Bend

Code	Angle	A	B	C
RB31	87°	49	115	138

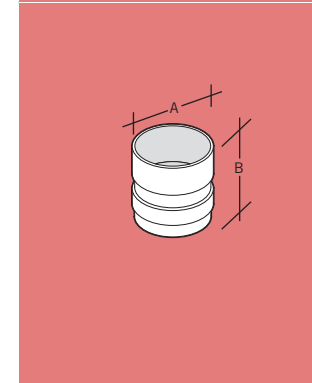

Socket

Code	A	B
RL3	87	103

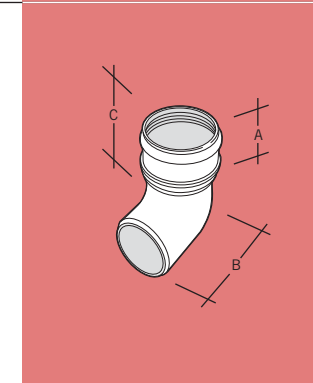

Bend

Code	Angle	A	B	C
RB33	45°	49	78	70

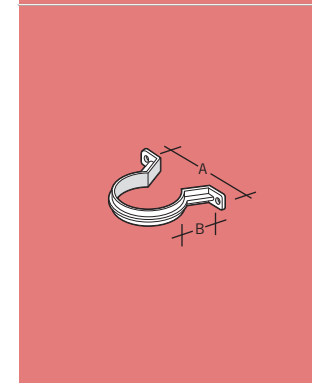

One piece pipe clip

Code	A	B
RC3	125	93

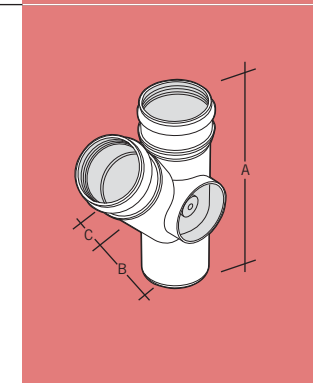

Branch

Code	Angle	A	B	C
RY3	45°	229	130	55

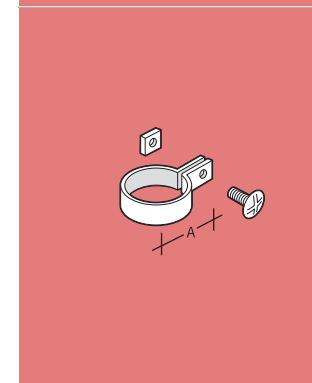

Pipe clip

Code	A
RC32	70

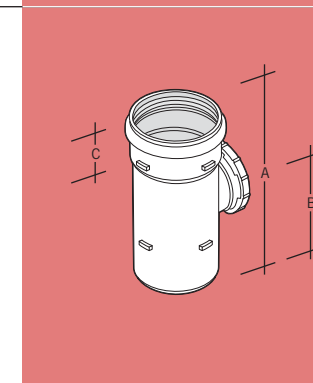

Access pipe

Code	A	B	C
RF3	205	101	52

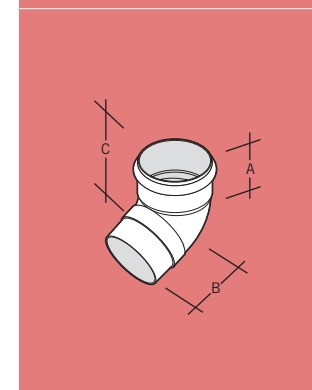

Offset bend

Code	Angle	A	B	C
RNE3	67°	43	78	76

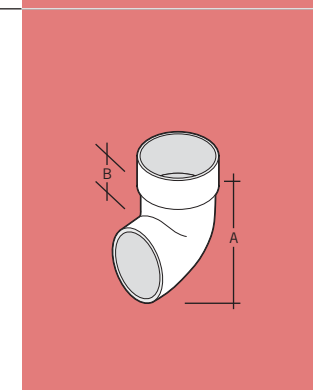

Shoe

Code	A	B
RS3	118	22

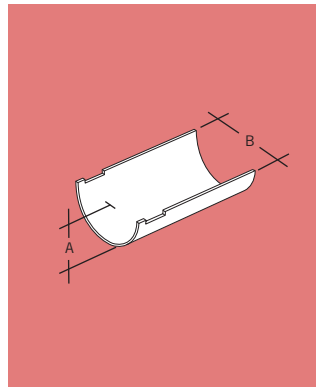

Gutter

Code	Nominal Length m	CSA mm ²	A	B
RGW4	4	8745	75	150

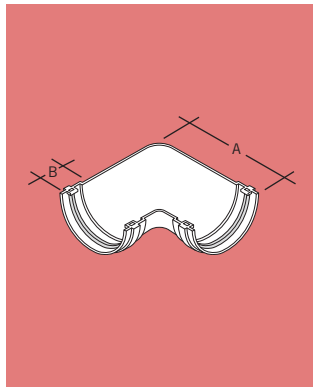

Angle

Code	Angle	A	B
RAW1	90°	234	44

Special gutter angles are available to order (RFB61)

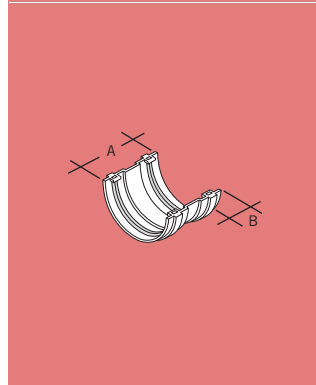

Union

Code	A	B
RUW1	121	44

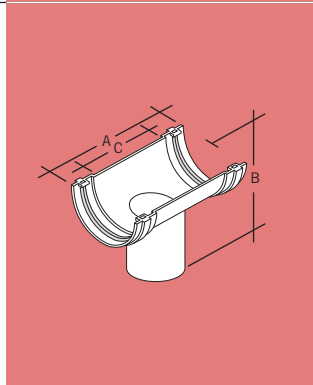

Running outlet

Code	A	B	C
ROW1	259	183	171

For use with 110mm downpipe

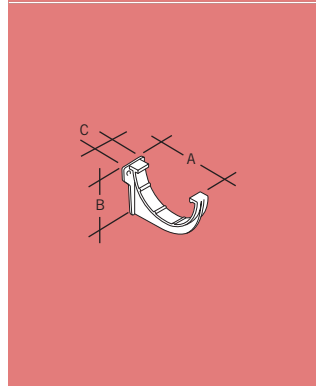

Fascia bracket

Code	A	B	C
RKW1	176	100	50

Two screw holes

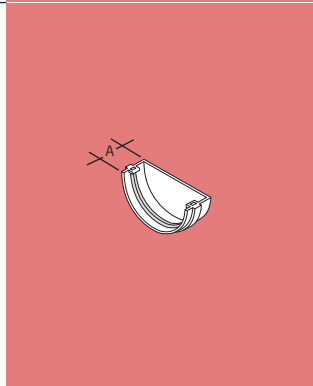

External stopend

Code	A
REV2	44

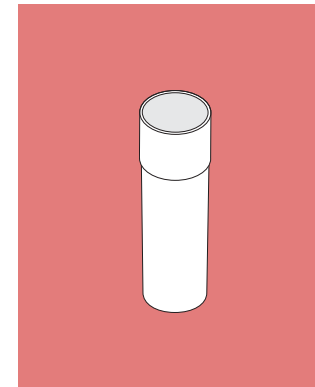

Pipe

Size mm	Code	Length m
110	● RP403	3

Formed socket
To BS 4576

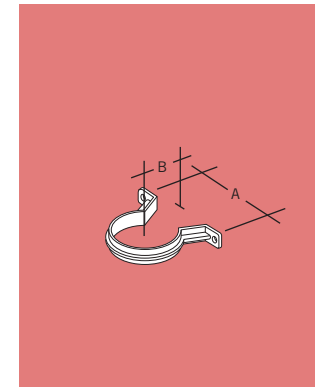

One piece pipe clip

Size mm	Code	A	B
110	■●● SC45	150	101

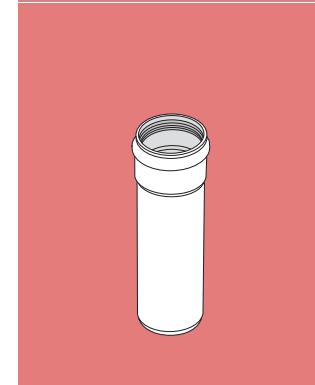

Pipe

Size mm	Code	Length m
110	■●● SP403	3
160	SP603	3

Ring seal socket/spigot
To BS 4514

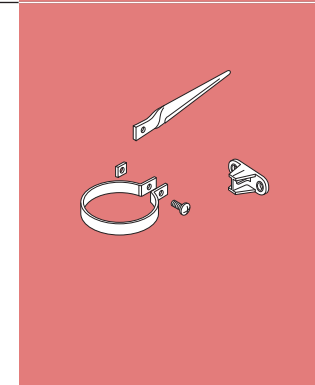

Pipe clip

Size mm	Code	For use with
110	● RPC1	Backplate RCB300 or drive-in spike RSS1

PVC coated mild steel, includes 6 x 20 mm nut and bolt

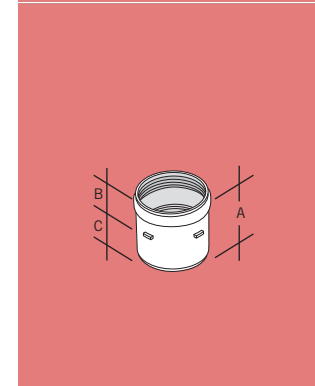

Loose pipe socket

Size mm	Code	A	B	C
110	■●● SE400	109	61	48
160	SE600	190	107	77

Ring seal socket/solvent socket

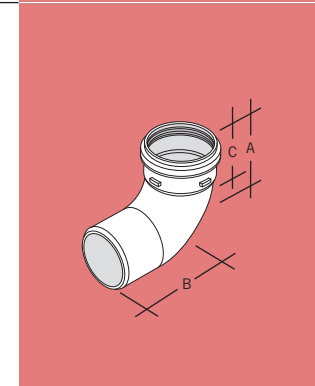

Bend

Size mm	Code	Angle	A	B	C
110	■●● SB41	87 1/2°	135	174	80

Ring seal socket/spigot

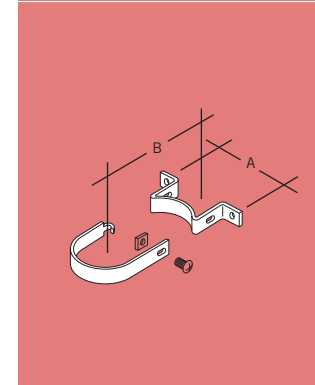

Socket clip

Size mm	Code	A	B
110	● SC41	152	101
160	SC61	240	121

PVC coated mild steel includes 6 x 20 mm nut and bolt

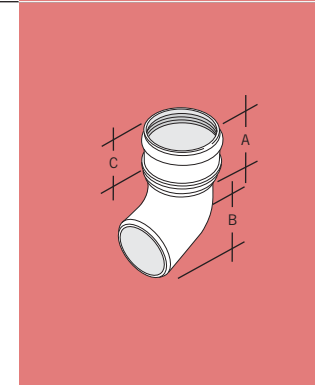

Short radius bend

Size mm	Code	Angle	A	B	C
110	■●● SB45	45°	145	125	80

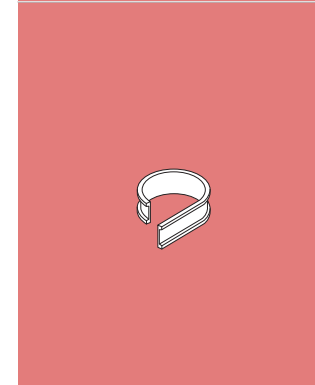

Barrel clip collar

Length m	Code
1	SC621

Cut to length for use with SC41/SC61
Flexible PVC

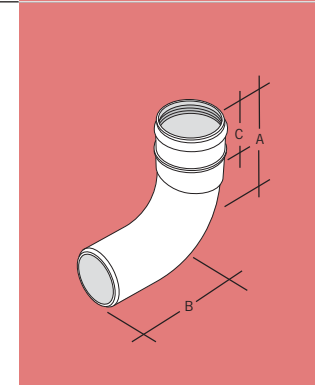

Adjustable bend

Size mm	Code	A	B	C
110	● SB47	210	205	82
160	SB67	285	275	96

Adjustable, 31-90°
Ring seal socket/spigot

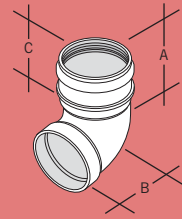

Offset bend

Size mm	Code	Angle	A	B	C
160	●SNE600	67½°	178	182	96

Ring seal socket/solvent socket

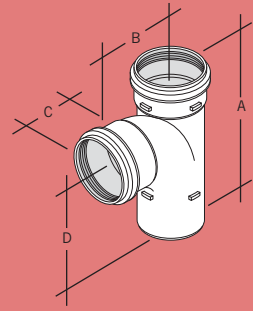

Branch

Size mm	Code	Angle	A	B	C	D
110	●SY401	87½°	300	150	60	175
160	●SY601	87½°	438	245	96	260

Ring seal socket/spigot

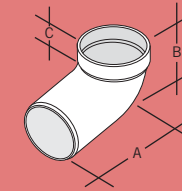

Offset bend

Size mm	Code	Angle	A	B	C
160	■SNE601	67½°	170	172	83

Solvent socket/spigot

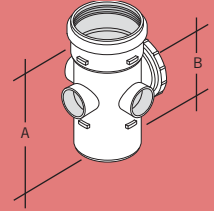

Access pipe

Size mm	Code	A	B
110	■SF41	244	123

Ring seal socket/spigot
SF41 - illustrated

Size mm	Code	A	B
110	●●SFS41	156	75
160	■SF611	287	142

Double solvent socket

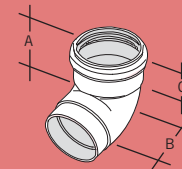

Offset bend

Size mm	Code	Angle	A	B	C
110	■RNE41	67½°	86	88	41

Solvent socket/spigot

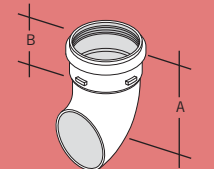

Shoe

Size mm	Code	A	B
110	●SS41	116	80
160	■SS61	211	92

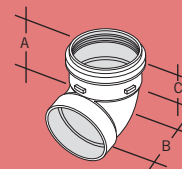

Offset bend

Size mm	Code	Angle	A	B	C
110	●SNE405	67½°	100	73	60

Ring seal socket/solvent socket

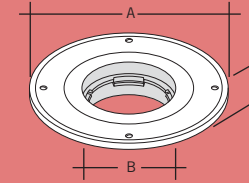

Universal flange

Code	A	B	C (Depth)
SOF1	343	180	55

Solvent socket
Flange 3 mm thick



Flat roof outlet grating

Code
SOF12

For use with SOF1



Balcony outlet grating

Code
SOB1

For use with SOF1

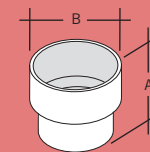

Straight flange connector

Size mm	Code	A	B
82	■SGS31G ▲	133	137
110	■SGS41W*†	139	134

Straight/solvent socket
*Available in White only

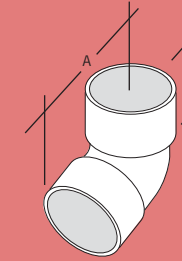

Bent flange connector

Size mm	Code	A	B
82	■ST310G	106	149
110	■STS41W*†	104	156

▲ Bent socket/spigot
† Bent socket/socket
*Available in White only

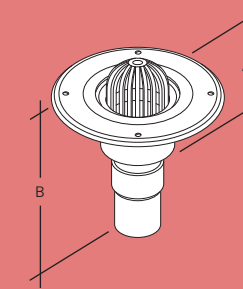

Flat roof outlet

Size mm	Code	A	B
68	■ROF25	343	506

Items supplied bagged loose for on site assembly

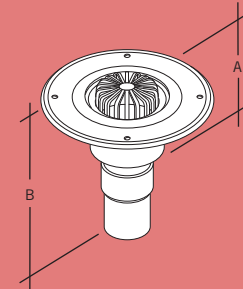

Balcony outlet

Size mm	Code	A	B
68	■ROB25	343	506

Including 305 mm extension spigot
Items supplied bagged loose for on site assembly

HOPPER HEADS

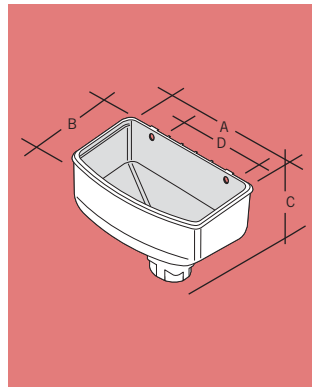

Hopper head

Size mm	Code	A	B	C	D
68	■ RH252	308	174	220	200

Dual spigot outlet
PVCu

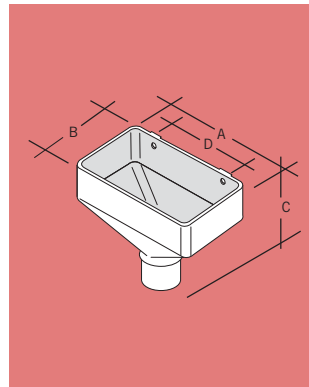

Hopper head

Size mm	Code	A	B	C	D
82	■ SH30	280	155	230	177

Circular spigot outlet
PVCu

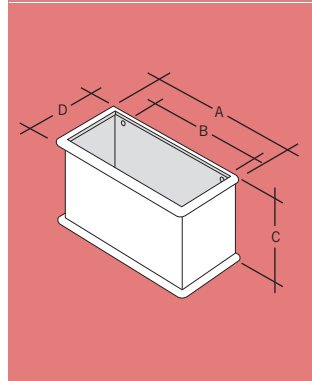

Hopper head

Size mm	Code	A	B	C	D
68	● RH25	425	298	238	190
110	SH40	425	298	238	190

● Black only Polyethylene

Circular spigot outlet
Available in black and grey

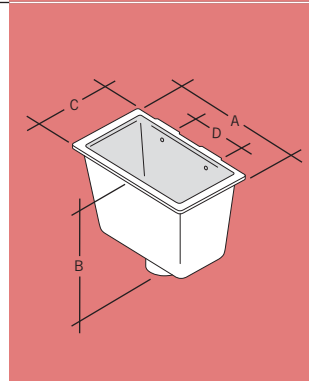

Hopper head

Size mm	Code	A	B	C	D
160	● SH60	406	375	248	254

Circular spigot outlet
Grey only GRP

ANCILLARY ITEMS

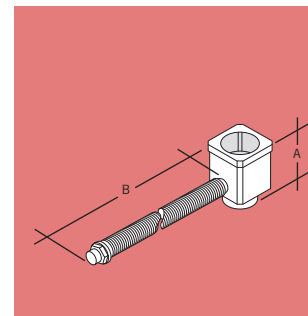

Rain diverter

Code	A	B
RD25R	105	500

Available in grey, black, white and chestnut brown

Suitable for use with both 68 mm round and 65 mm square PVCu downpipes

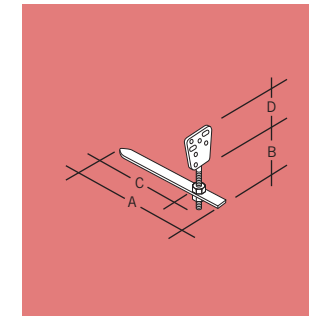

Rise & fall extension arm

Code	A	B	C	D
RKF1	290	100	235	67

Electro-plated mild steel including two cadmium plated nuts and bolts
3/8" Whitworth bolt

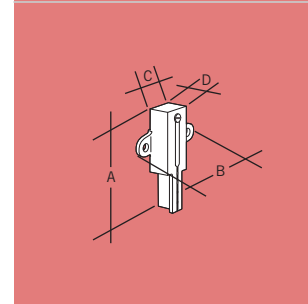

Fascia bracket spacer/height adjuster

Code	A	B	C	D
RGS1	94	48	17	17

Available in black and white

Including nut and bolt

Suitable for use with Deepflow, Clip-master, Flowline and Classic fascia brackets.

Provides 25mm height adjustment

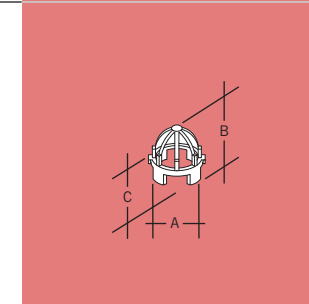

Leaf guard

Code	A	B	C
RV225	64	55	18

Available in Black, Grey, White and Chestnut Brown

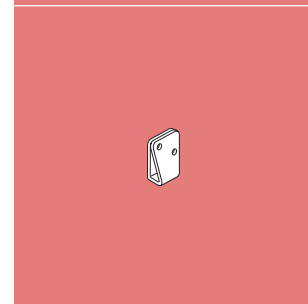

Angled fascia bracket adaptor

Code	Angle
RKA1	22 1/2°
RKA2	30°

Galvanised mild steel

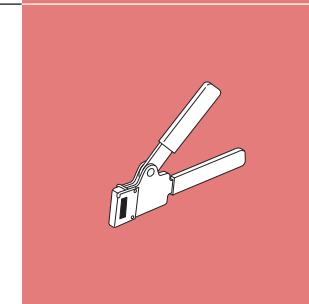

Universal gutter notching tool

Code
RGN1

For use with Deepflow, Deepflow150, Clip-master and Flowline gutters

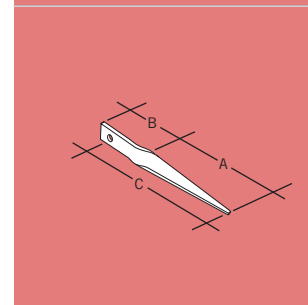

Drive-in spike

Code	A	B	C	D
RSS1	115	58	154	19

Galvanised mild steel



Solvent cement

Code	Size ml
KS2	55 tube
KS10	250 can and brush

For socket and offset construction. Conforms to BS 6209: 1983. All cans and tubes carry date of manufacture and should be used within twelve months of this date

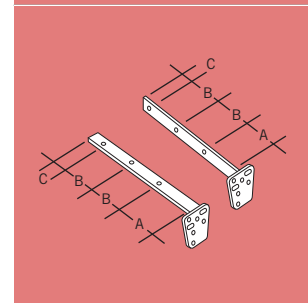

Rafter arm (fixed)

Code	Angle	A	B	C
Side RSA1	22 1/2°	50	75	25
Top RTA1	22 1/2°	100	75	25

Electro-plated mild steel including two 6 x 20 mm cadmium plated nuts and bolts



Silicone lubricant

Size	Code
56g	SZ56 tube
100g	SZ100 tub
400ml	SZ400 aerosol can
500g	SZ500 tub

Ozone friendly SZ400 non flammable, C.F.C. free propellant

Water research centre approved

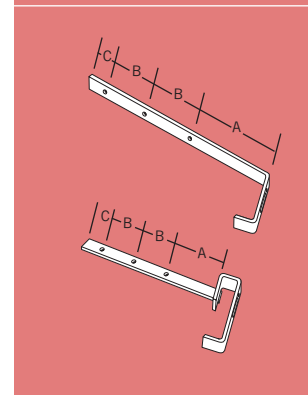

Rafter arm (adjustable)

Code	A	B	C
Side RSA1A	123	75	25
Top RTA1A	65	75	25

Galvanised steel including nut, bolt and antislip washer

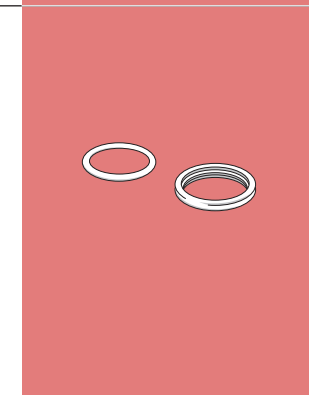

Spare ring seals

Size mm	Code	Code
68	RR25	for use with RLR25
82	SR31	SR31T
110	SR41	SR41T
160	SR61	SR61T

PVCu pipe/fittings

Spare nuts & bolts

Size mm	Code
12 x 5	RNB21 (For use with rafter arms)
20 x 6	RNB11 (For use with pipe clip)

The Marley Rainwater Installation Guide

General Gutter position

It is important to ensure gutters are fitted as high as possible to the roof edge. The eaves course of tiles should not project too far over the gutter. It is recommended gutters are sized to be fitted level and care is taken to limit the tile overhang from the fascia board to 50mm. This applies to 112-120mm nominal width gutters. For wide gutters the overhang should not exceed the centre line. Where over fascia ventilation is used, it may be necessary to use a gutter spacer and height adjuster bracket in conjunction with fascia brackets to ensure the gutter is fitted in the optimum position.

Fascia brackets

Gutter fascia brackets should be fixed in the conventional manner with the aid of a string line to maintain alignment. Bracket spacing must not exceed 1 metre centres and should be secured to the fascia board with two 1" x 8g (25 x 4mm) non-ferrous round head screws. Some fascia brackets feature an optional single screw fixing and where this is used a larger 1 1/4" x 10g (32 x 5mm) round head screw should be used. In areas subject to heavy snow fall it is recommended that the two screw fixing method is adopted and bracket centres are reduced as a precaution. When fixing to cellular fascia board it is recommended that parallel thread screws are used which should be long enough to penetrate the rear face of the board. Two fixing screws should be used and boards of less than 16mm thick should have a timber support batten fitted behind to ensure a secure fixing is obtained. Where gutter fittings have multiple fixing holes it is recommended these are used particularly when fixing to cellular fascia boards to improve the snow load characteristics of the installation.

A choice of top hung internal, RCK52, or conventional external, RCK51, fascia brackets are available with the Classic gutter system.

Gutter brackets

Gutter unions, outlets and stopends must have a fascia bracket fitted within 150mm of one side of the fitting for support. Internal and external angles require supporting brackets positioned on both sides within 150mm.

Rafter arm brackets

Occasionally it may be necessary due to the eaves construction to use an alternative method for fixing gutter brackets. Rafter arm brackets can be used with all Marley gutter systems. Additional structural fixings should be provided when used with a clip-jointed gutter system, to enable key fittings to be anchored and supported for the control of thermal movement.

Therefore, it is recommended that notched gutters are used on buildings without fascia boards as key fittings such as unions and outlets do not need to be secured and can be positioned adjacent to structural fixing points. Top rafter brackets, RTA1 or RTA1A, will need to be fitted before the roof is tiled. Side rafter brackets, RSA1 or RSTA1A, may be fitted afterwards and are easily adjusted to accommodate minor variations in line and level. Two cadmium plated nuts and bolts are supplied with each bracket to secure fascia brackets to the multi-fit face plate. Although fixings are controlled by rafter centres it is important to meet gutter support recommendations previously described.

Rise and fall brackets

Rise and fall brackets, RKF1, can be used with clip jointed gutters although a notched system is recommended as described for rafter arm fixing above. Two cadmium plated nuts and bolts are supplied with each bracket to secure fascia brackets to the multi-fit face plate. It is recommended that pilot holes are drilled in mortar joints before the spike is driven in to avoid cracking the brickwork bond.

Angle fascia bracket adaptor

Angle fascia bracket adaptors, RKA1, RKA2, are required when a sloping fascia board is employed at the eaves. The galvanised mild steel adaptor is fitted behind the fascia bracket with two 1 3/4" x 10g (45 x 5mm) non-ferrous round head screws passing through both bracket and adaptor.

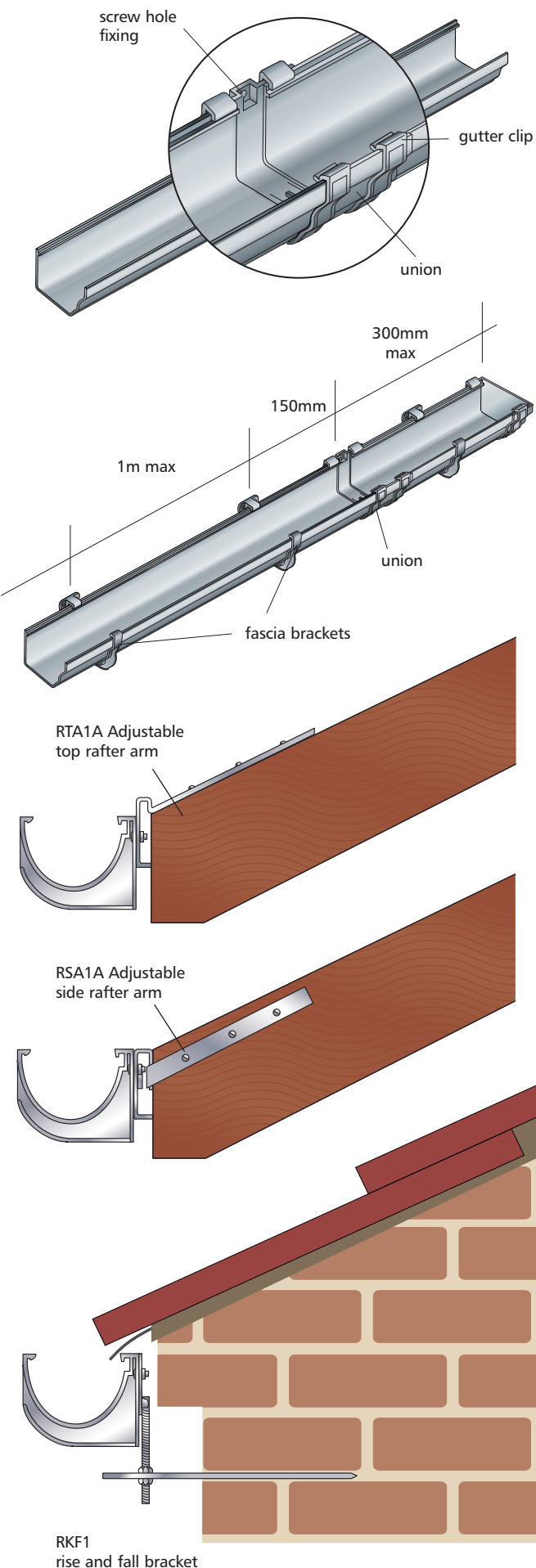

Gutter jointing Clip-jointed gutter systems

Classic and Miniline systems are jointed by means of pre-fitted clips on all fittings. Deepflow, Deepflow150, Clip-master and Flowline systems are jointed via the innovative Easyclip which makes it simple to joint the gutter and fitting, but it is also very easy to take apart if necessary.

Each joint is made by inserting the plain edge of gutter into the fitting and locating under the rear clip. At the same time ease the front edge of fitting forward and up until the gutter clips under the front edge. Care must be taken to ensure that each length of gutter is fitted to the insertion mark on each fitting. This is particularly important and attention to this will ensure trouble free performance for many years.

Unions and outlets incorporate fixing holes in the rear edge which must be used to secure the fitting to the fascia board. This is essential for the control of thermal movement that occurs with temperature variations. The length of gutter to a stopend from a fitting must not exceed 300mm. Where this is exceeded a union must be fitted and secured as previously described with a short piece of gutter to the stopend. On Deepflow, Deepflow150, Clip-master and Flowline the length of gutter to a stopend can be retained using the notch technique and adaptor RGNA1 to eliminate the above restriction.

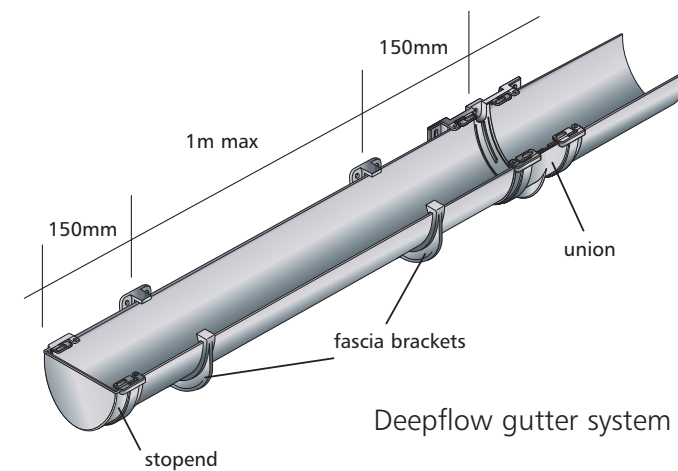

Deepflow gutter system

Notched gutter systems

The well proven notch technique is employed on the Industrial gutter system. Integrally moulded retaining nibs on gutter fittings allow simple on site assembly as the synthetic rubber seal is compressed by the gutter to form a watertight joint.

To assemble a joint, locate the notched end of gutter into the fitting under the retaining nib on the back edge, ease the front of the fitting forward and down until the gutter clips under the retaining nib on the front edge. Finally, line up the gutter so that the nib is in the centre of the notch. When correctly assembled a notched joint cannot pull apart and will absorb expansion and contraction associated with variations in temperature while maintaining a watertight seal.

Where lengths of gutter are cut new notches must be formed, this can be done using a purpose made notching tool RGN1. Alternatively, notches may be filed using a notched length of gutter as a template.

Deepflow, Deepflow150, Clip-master and Flowline can also be installed as notched systems. Notches must be made to both ends of a length of gutter but only on the rear edge of the gutter using the notching tool. A notch adaptor RGNA1 is then inserted into the Easyclip from the underside, between the gap in the body of the fitting and the clip arm. Insert one end of the short side of the adaptor into the open end of the Easyclip as shown in figure A. Twist the other side of the adaptor into place. The adaptor is necessarily a tight fit to ensure it stays in place. The notched gutter end is located under the notch adaptor and the joint clipped together at the front as shown in figure B.

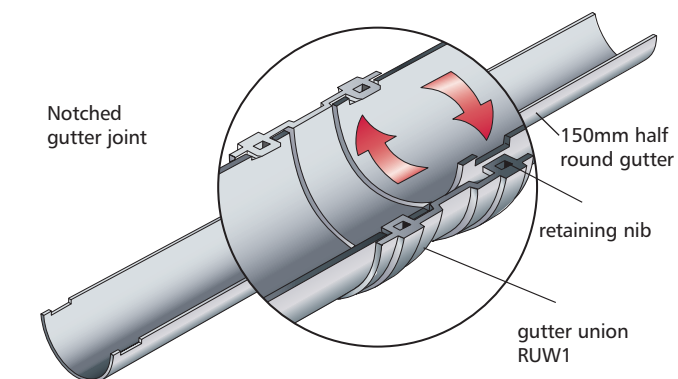

Industrial gutter system

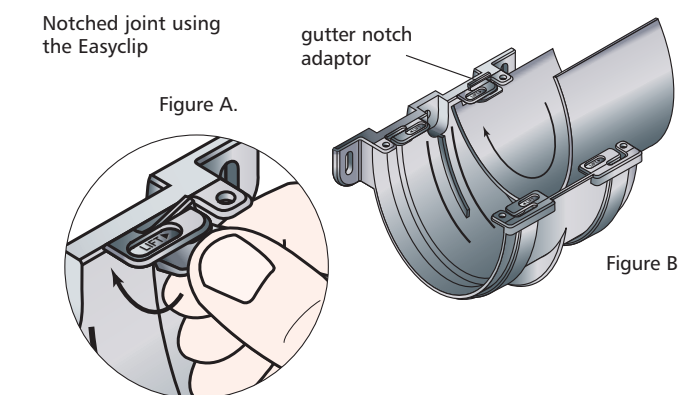

Circular downpipe systems

Marley Deepflow, Classic, Flowline and Clip-master gutters all have outlets designed to suit 68mm circular downpipes. This diameter of downpipe has sufficient capacity to accommodate the maximum flow from all of the above gutter systems.

As rainwater pipes are generally fitted externally, joints between each spigot and socket length do not need to be sealed. However offset fittings are sized to allow for push fit or solvent weld jointing.

Gutter outlets are normally positioned directly above drain connections but on occasions it may be necessary to rotate the offset to avoid obstructions below. This can occur at the base of a valley where an outlet is located close to an internal gutter angle.

Offset assembly

Offsets can be easily constructed on site from a range of bends depending on the roof overhang at the eaves. The RNE255 and RB252 bends are used to accommodate most soffit widths but other combinations may be adopted.

Where offsets exceed 600mm it is recommended that bends are solvent welded to gutter outlet spigots to ensure a positive connection. When two 87½° bends are used to construct an offset the horizontal section of pipe should be supported with a pipe clip from the soffit. Small offsets can be achieved using offset bends RNE252 and RNE253 where a minimum projection of 25mm is obtainable.

Location of pipe clips

Every rainwater pipe should have a clip located round the top socket to support the downpipe system. Intermediate clips should then be located at a maximum of 1.8m centres or in the middle of each length to maintain alignment. A gap of 10mm should be left between the end of each pipe and the bottom of the socket to allow for thermal movement.

Two different pipe clip fixing methods are available. A one piece clip RCZ253, for flush fixing or alternatively RC252/RC251 are available to fit both the downpipe and pipe socket, these are used with backplate RCB300 and allow for adjustment. Each should be secured with two 32 x 6.5mm non-ferrous round head screws. An extension backplate can also be used for greater adjustment of the downpipe from the wall. The installation procedure described above also applies where 51mm and 110mm downpipes are fitted to Miniline and Industrial gutter systems.

Drain connections

External rainwater pipes usually connect direct to the surface water drain or via a gully hopper. Where a direct connection is made a reducer and a short section of pipe is used to provide the transition between different pipe sizes. A gully trap will be required to both arrangements where the drain connects to a combined foul and surface water drainage system.

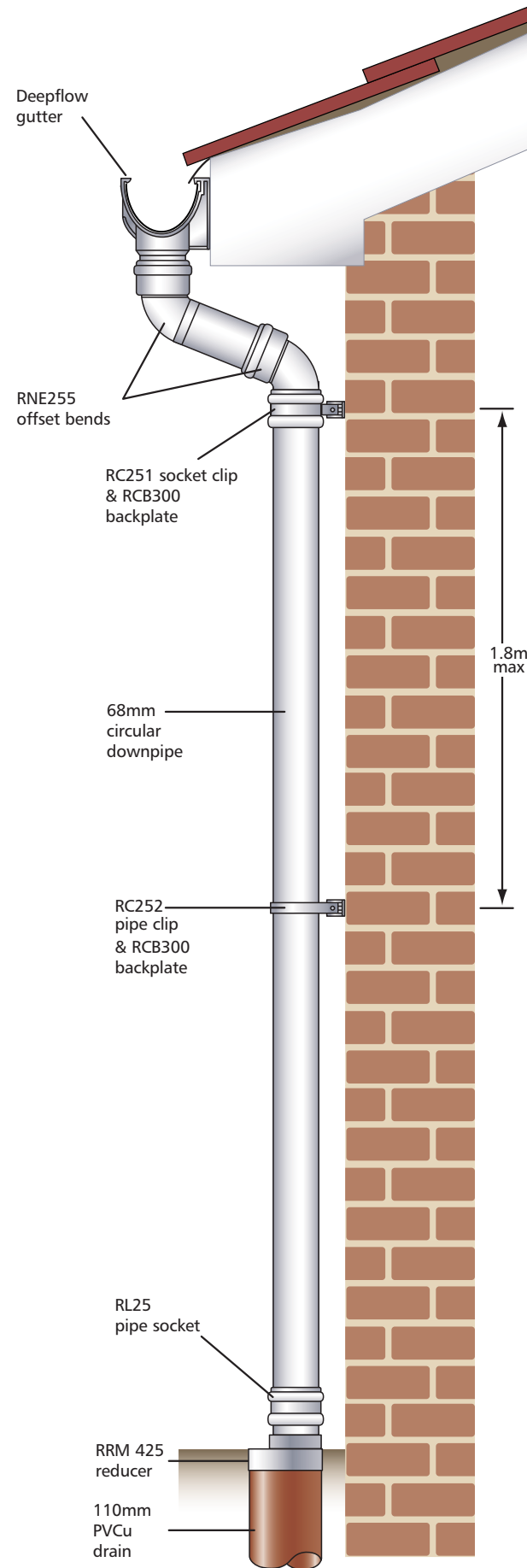
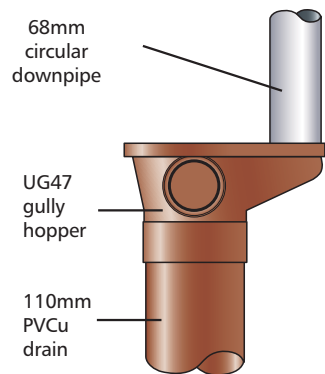

Square downpipe systems

Marley Flowline and Classic gutter systems are available with outlets suitable for 65mm square and 68mm circular rainwater pipes. For aesthetic reasons, the 65mm square system is normally preferred but both have sufficient capacity to accommodate the maximum flow from either system.

As rainwater pipes are generally fitted externally, joints between each length do not need to be sealed. However, offset fittings are sized to allow for push fit or solvent weld jointing.

Care should be taken to ensure gutter outlets are positioned directly above the rainwater drain connection. This is important as offsets cannot be rotated on square downpipes.

Where a RH25 hopper head is used, the RLE3 outlet adaptor with a pipe socket are required to provide the necessary transition from circular to square.

Offset assembly

Offsets can be easily constructed on site from a range of bends depending on the roof overhang at the eaves. The RBE1 offset bend is used to accommodate most soffit widths but the RBE3 bend can be used for wider projections.

Where offsets exceed 600mm it is recommended that bends are solvent welded to the gutter outlet spigot to ensure a positive connection. When two 87½° bends are used to construct an offset the horizontal section of pipe should be supported with a pipe clip from the soffit. The minimum offset that can be achieved using two RBE1 bends is 80mm but a smaller 50mm offset is possible if the one piece fitting RNE1 is used.

Location of pipe clips

Every rainwater pipe should be supported at the top with a clip. Intermediate clips should be located at a maximum of 1.8m centres or in the middle of each length to maintain alignment. A gap of 10mm should be left between the end of each pipe and bottom of the socket to allow for thermal movement.

Two different pipe clip fixing methods can be used for square downpipes. A one piece clip RCE1, for flush fixing or alternatively the RCE2 clip with backplate RCB300 can be used to allow for adjustment. Each should be secured with two 32 x 6.5mm non-ferrous round head screws. An extension backplate can also be used to vary the distance of the downpipe from the wall.

Drain connections

External rainwater pipes usually connect direct to the surface water drain or via a gully hopper. Where a direct connection is made a reducer is used to provide the transition between different pipe sizes. A gully trap will be required to both arrangements where the drain connects to a combined foul and surface water drainage system.

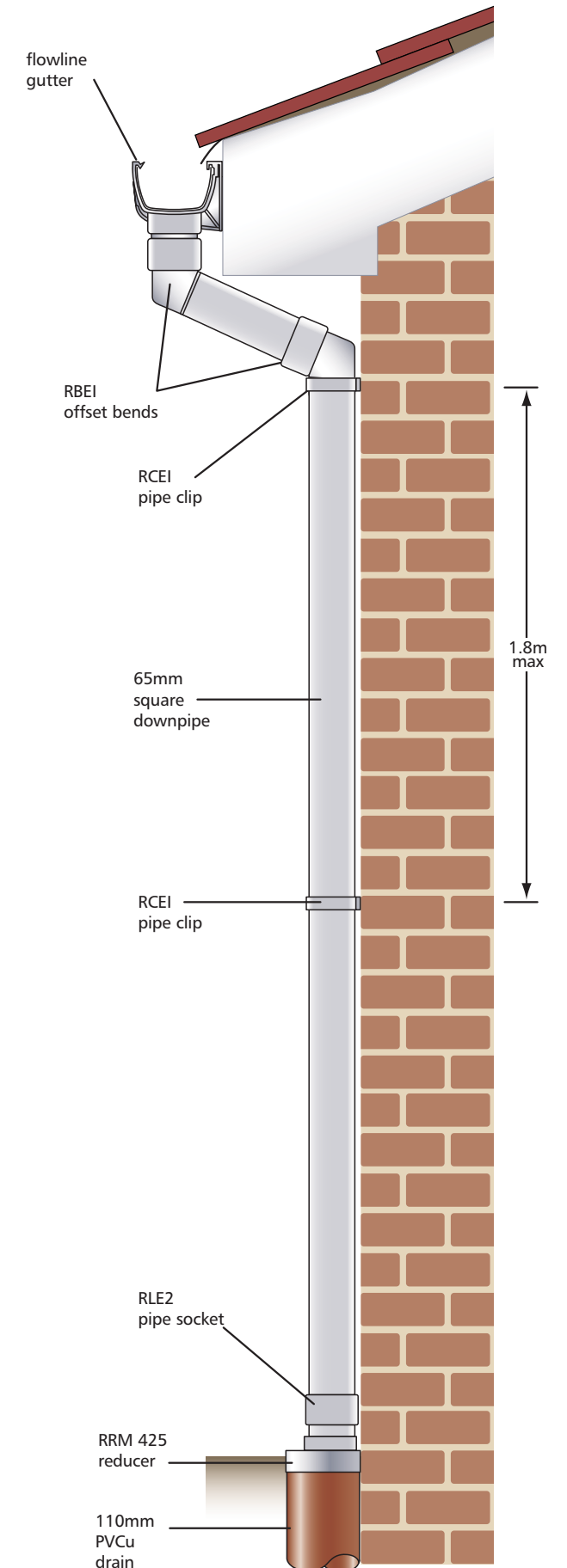
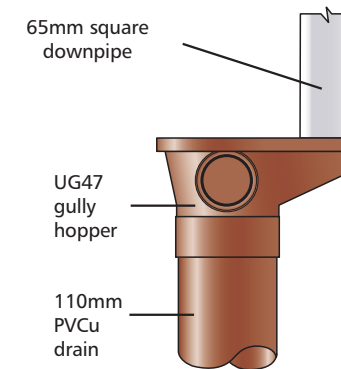

Roof and balcony outlets

Marley flat roof outlets are suitable for use with single skin PVC roofing membranes, multi-layer built up felt roofs and bituminous waterproofing systems.

Two types of outlet gratings are available, a domed flat roof grating and a balcony version that provides a flush finish when used with asphalt construction.

Each grating is secured by a quarter turn twist and lock action to the outlet flange. This provides easy access for maintenance and removal of any debris that may accumulate around the outlet.

Four screw holes are provided in the circular flange to enable a secure fixing to be made to the roof structure. Straight or bent connectors are used to connect to 110mm PVCu pipework which can be reduced to 82mm without any detrimental effect on the outlet performance.

Outlets ROF25 and ROB25 are supplied bagged with loose components for on site assembly to suit 68mm circular downpipes.

Where this size of downpipe is used internally, the pre-formed socket on the pipe must be removed and the RLR25 socket and RR25 seal used to ensure a watertight joint is achieved.

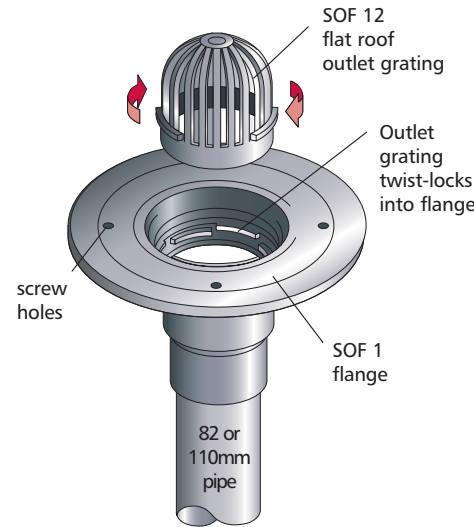

Flow capacity

The flow characteristics of different size flat roof outlets is shown below and is based on a rainfall intensity of 0.021 litres/second per square metre of roof area. BS EN 12056-3:2000 recommends a maximum head over the outlet of up to 35mm for flat roof applications.

Outlet	Head of water over the outlet				
	15mm	20mm	25mm	30mm	35mm
ROF25 68mm	1.0l/s 48m ²	1.91l/s 91m ²	2.62l/s 125m ²	3.52l/s 168m ²	4.53l/s 216m ²
ROB25 68mm	1.0l/s 48m ²	1.91l/s 91m ²	2.92l/s 139m ²	4.03l/s 192m ²	5.14l/s 245m ²
SOF1/SOF12 82 or 110mm	1.0l/s 48m ²	1.91l/s 91m ²	2.92l/s 139m ²	4.03l/s 192m ²	5.33l/s 254m ²

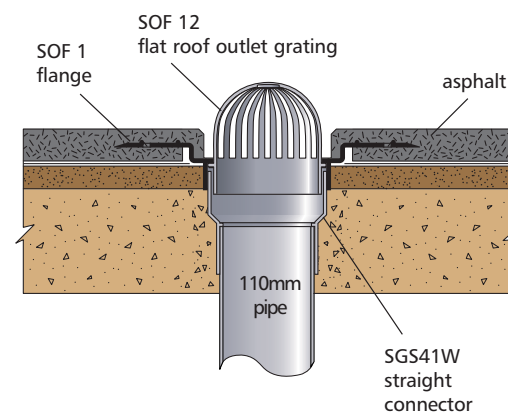

Hopper heads

The flow capacities of different size hopper heads are shown in the table below and are based on the same rainfall intensity used for that of flat roof outlets above.

Product Code	Pipe Size	Roof Area m ²	Flow rate litres/second
RH252	68mm	247m ²	5.14l/s
RH25	68mm	360m ²	7.56l/s
SH30	82mm	196m ²	4.11l/s
SH40G	110mm	720m ²	15.12l/s
SH40B	110mm	720m ²	15.12l/s
SH60	160mm	935m ²	19.63l/s

Alutec range^o

A separate product guide showing the wide range of aluminium outlets for roof, floor and shower applications is also available.

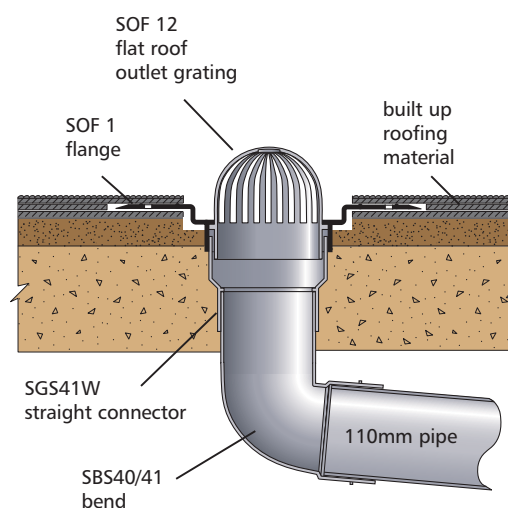

Inspection and testing

All newly installed gutters and pipework should be tested in accordance with the appropriate standards. These requirements may vary according to locality of installation and, for guidance, attention is drawn to BS 8000 Workmanship on Building Sites and BS EN 12056-3: 2000, Gravity drainage inside buildings.

Handling

PVCu gutters and pipes are strong, though lightweight, and are therefore easily handled. However reasonable care should be exercised whilst handling in extremely cold conditions.

To protect the high gloss level of Life⁴ gutter and downpipes, they are packed into thick plastic sleeving to prevent accidental damage. When removing from sleeving, ensure that the external face is uppermost and handle with care to ensure that the profiles do not rub against each other.

To preserve the appearance of the self-coloured material, when products are delivered to site, they should preferably be placed inside a storage building.

Storage

Gutters and pipes should be well supported on suitable racks. Dividing the framework or shelves into sections helps to segregate different products and prevents overloading and possible distortion of bottom layers.

Pipes and gutter bundles should be stacked no more than seven high. If it is necessary to store in the open for long periods, or if products are to be exposed to strong sunlight, they should be covered with an opaque sheet. Fittings supplied in cardboard boxes or polythene bags should be stored under cover and kept packed until required.

Solvent cement must be securely stored in a cool place out of direct sunlight and away from any heat source.

Safety

The relevant regulations are outlined in the Health and Safety at Work Act 1974 and should be followed. Hazard sheets, dealing with the potential hazards of working with solvent cement and silicone lubricant are available from Marley Plumbing & Drainage.

Refer to C.D.M. regulations (Code of Practice and Designing for Health and Safety in Construction 1995).

Snow Loading

All Marley PVCu gutter brackets featured in this guide have been subjected to simulated snow loading tests as detailed in BS 4576: Part 1/BS EN 1462 and perform in excess of Class H (Heavy) requirements.

However, in areas where particularly high snow falls and severe icing might be expected, it is recommended that snow boards be fitted to the eaves of the pitched roofs. This precaution should also be considered wherever sliding snow might cause damage or injury to structures or persons below.

Maintenance

Marley PVCu Rainwater systems are corrosion resistant and self-coloured, the material therefore does not require painting. If, however, at any time painting is required, a paint specific for use with PVC is recommended.

Timber fascias that have been treated with timber preservatives should be allowed to dry before fixing Marley PVCu eaves gutters.

